

Roof Top Units

RTU-1/2/3/4



Mechanical Limited

Project	<u>Upgrade HVAC System - BN149932</u>
Work Order	15-017
Item	Roof Top Units - RTU-1/2/3/4
Section / Page	1
Specification	23 74 00
Date	October 9, 2015
Checked by	<i>M.G.</i>
Drawing Revision	Original
Supplier	Trane Canada
Consultant	<u>Defense Construction Canada</u>
Project Number	L-B147-5259/100



Submittal

Prepared For:
Moon-Matz Ltd.

Date: October 05, 2015

Sold To:
Sexton's Mechanical Ltd.

Job Name:
DND CFB Borden Building P-154

Trane Canada ULC is pleased to provide the enclosed submittal for your review and approval.

Product Summary

Qty	Product
1	3-10 Ton R410A PKGD Unitary Gas/Electric Rooftop (RTU-2)
3	Packaged Gas/Electric Rooftop Units (RTU-1, RTU-3, RTU-4)

Peter Nguyen
Trane Canada ULC
4051 Gordon Baker Road
Scarborough, ON M1W 2P3

Phone: (416) 847-2844
Cell: (647) 400-6853
Email: peter.nguyen@trane.com

Cc: Waleed Adham / Carmine Bozzo
Trane Canada ULC
110 Lancing Drive
Building 1, Unit 3
Hamilton, ON L8W 3A1
Phone: (905) 308-7780 ext.21
Cell: (905) 516-9883
Email: waleed.adham@trane.com

The attached information describes the equipment we propose to furnish for this project, and is submitted for your approval.

Table Of Contents

Product Summary 1

3-10 Ton R410A PKGD Unitary Gas/Electric Rooftop (Item A1)..... 3

 Tag Data 3

 Product Data 3

 Performance Data 3

 Mechanical Specifications 5

 Unit Dimensions 8

 Weight, Clearance & Rigging Diagram..... 12

 Accessory 14

 Accessory 15

 Accessory 16

Packaged Gas/Electric Rooftop Units (Items B1 - B3) 20

 Tag Data 20

 Product Data 20

 Performance Data 20

 Mechanical Specifications 22

 Unit Dimensions 25

 Weight, Clearance & Rigging Diagram..... 29

 Accessory 34

Field Installed Options - Part/Order Number Summary 45

 3-10 Ton R410A PKGD Unitary Gas/Electric Rooftop..... 45

 Packaged Gas/Electric Rooftop Units 45

Tag Data - 3-10 Ton R410A PKGD Unitary Gas/Electric Rooftop (Qty: 1)

Item	Tag(s)	Qty	Description	Model Number
A1	RTU-2	1	7.5 Ton R410A PKGD Unitary Gas/Electric	YHC092FWRYA--

Product Data - 3-10 Ton R410A PKGD Unitary Gas/Electric Rooftop**Item: A1 Qty: 1 Tag(s): RTU-2**

DX cooling, gas heat
 High efficiency
 Convertible configuration - **Horizontal**
 7.5 Ton Dual compressor
 575/60/3
 Microprocessor controls 3ph
 Gas Heat – Modulating (4:1 Turndown ratio)
 Medium gas heat stainless steel heat exchanger
 Economizer Comparative Enthalpy 0-100%
 True VAV w/std motor
 Discharge Air Sensing Tube (Field)
 Froststat (Field)
 Hinged panels/2 in pleated filters Merv 8
 Through the base electrical 3ph
 Non-fused disconnect
 BACnet Communications Interface 3ph
 Special Roof curb with 1" deflection vibration isolation (Field)
 Power Exhaust – RA Duct mounted (Field)
 Digital display zone sensor (Field)

Performance Data - 3-10 Ton R410A PKGD Unitary Gas/Electric Rooftop

Tags	RTU-2
Design Airflow (cfm)	2700
Airflow Application	Horizontal
Cooling Entering DB (F)	78.00
Cooling Entering WB (F)	64.00
Ent Air Relative Humidity (%)	46.60
Ambient Temp (F)	95.00
Evap Coil Leaving Air Temp (DB) (F)	54.93
Evap Coil Leaving Air Temp (WB) (F)	52.89
Cooling Leaving Unit DB (F)	56.83
Cooling Leaving Unit WB (F)	53.68
Gross Total Capacity (MBh)	86.37
Gross Sensible Capacity (MBh)	67.28
Gross Latent Capacity (MBh)	19.09
Net Total Capacity (MBh)	82.20
Net Sensible Capacity (MBh)	63.11
Heating EAT (F)	70.00
Heating LAT (F)	111.40
Heating Delta T (F)	41.40
Input Heating Capacity (MBh)	150.00
Output Heating Capacity (MBh)	120.00
Output Heating Cap. w/Fan (MBh)	124.18
Design ESP (in H2O)	1.498
Component SP (in H2O)	0.125
Indoor mtr operating power (bhp)	1.51
Indoor RPM (rpm)	1278
Indoor Motor Power (kW)	1.13
Outdoor Motor Power (kW)	0.71
Compressor Power (kW)	6.05
System Power (kW)	7.88
IPLV @ AHRI (IPLV)	14.5
MCA (A)	15.60

Tags	RTU-2
MOP (A)	20.00
Compressor 1 RLA (A)	5.10
Compressor 2 RLA (A)	3.70
Evaporator fan FLA (A)	3.10
Condenser fan FLA (A)	2.40
Min. unit operating weight (lb)	1026.0
Max. unit operating weight (lb)	1291.0
Fan motor heat (MBh)	4.18
Dew Point (F)	51.38
Rated capacity (AHRI) (MBh)	89.00
Exhaust fan power (kW)	0.65
Refrig charge (HFC-410A) - ckt 1 (lb)	5.5
Refrig charge (HFC-410A) - ckt 2 (lb)	4.2
ASHRAE 90.1	Yes
Saturated Suction Temp Circuit 1 (F)	49.29
Saturated Discharge Temp Circuit 1 (F)	115.28
Saturated Suction Temp Circuit 2 (F)	51.26
Saturated Discharge Temp Circuit 2 (F)	112.61
EER @ AHRI Conditions (EER)	12.6
Total Static Pressure (in H2O)	1.623

Tons	Unit Model Number	Octave Center Frequency								Overall dBA
		63	125	250	500	1000	2000	4000	8000	
3	T/YSC036E	79	85	79	79	77	71	67	58	81
4	T/YSC048E	82	84	83	80	76	72	66	58	82
5	T/YSC060E	85	82	81	81	77	72	67	61	82
6	T/YSC072F	91	95	90	87	84	79	75	68	89
7½	T/YSC090F	91	95	90	87	84	79	75	68	89
7½	T/YSC092F	92	96	92	89	85	80	76	69	91
8½	T/YSC102F	91	95	90	87	84	79	75	68	89
10	T/YSC120F	91	86	90	86	82	78	73	67	88
3	T/YHC036E	79	85	79	79	77	71	67	58	81
4	T/YHC048E	80	86	84	85	83	79	73	67	87
4	T/YHC048F	80	86	84	85	83	79	73	67	87
5	T/YHC060E	80	86	84	85	83	79	73	67	87
5	T/YHC060F	80	86	84	85	83	79	73	67	87
6	T/YHC072F	91	95	90	87	84	79	75	68	89
7½	T/YHC092E	89	87	91	85	80	77	73	66	87
7½	T/YHC092F	91	86	90	86	82	78	73	67	88
8½	T/YHC102E	89	87	91	85	80	77	73	66	87
10	T/YHC120E	89	87	91	85	80	77	73	66	87

Note: Tests follow ARI270-95.

Mechanical Specifications - 3-10 Ton R410A PKGD Unitary Gas/Electric Rooftop**Item: A1 Qty: 1 Tag(s): RTU-2****General**

The units shall be convertible airflow. The operating range shall be between 115°F and 0°F in cooling as standard from the factory for units with microprocessor controls. Operating range for units with electromechanical controls shall be between 115°F and 40°F. Cooling performance shall be rated in accordance with ARI testing procedures. All units shall be factory assembled, internally wired, fully charged with R-410A, and 100 percent run tested to check cooling operation, fan and blower rotation, and control sequence before leaving the factory. Wiring internal to the unit shall be colored and numbered for simplified identification. Units shall be cULus listed and labeled, classified in accordance for Central Cooling Air Conditioners.

Casing

Unit casing shall be constructed of zinc coated, heavy gauge, galvanized steel. Exterior surfaces shall be cleaned, phosphatized, and finished with a weather-resistant baked enamel finish. Unit's surface shall be tested 672 hours in a salt spray test in compliance with ASTM B117. Cabinet construction shall allow for all maintenance on one side of the unit. Service panels shall have lifting handles and be removed and reinstalled by removing two fasteners while providing a water and air tight seal. All exposed vertical panels and top covers in the indoor air section shall be insulated with a cleanable foil-faced, fire-retardant permanent, odorless glass fiber material. The base of the unit shall be insulated with 1/8 inch, foil-faced, closed-cell insulation. All insulation edges shall be either captured or sealed. The unit's base pan shall have no penetrations within the perimeter of the curb other than the raised 1 1/8 inch high downflow supply/return openings to provide an added water integrity precaution, if the condensate drain backs up. The base of the unit shall have provisions for forklift and crane lifting, with forklift capabilities on three sides of the unit.

Unit Top

The top cover shall be one piece construction or, where seams exist, it shall be double-hemmed and gasket-sealed. The ribbed top adds extra strength and enhances water removal from unit top.

Two-Inch Pleated Filters

2" pleated media filters shall be available on all models.

Compressors

All units shall have direct-drive, hermetic, scroll type compressors with centrifugal type oil pumps. Motor shall be suction gas-cooled and shall have a voltage utilization range of plus or minus 10 percent of unit nameplate voltage. Internal overloads shall be provided with the scroll compressors.

Dual compressors are outstanding for humidity control, light load cooling conditions and system back-up applications. Dual compressors are available on 7½-10 ton models and allow for efficient cooling utilizing 3-stages of compressor operation for all high efficiency models.

Notes:

Crankcase heaters are optional on YSC (036, 048, 060, 072, 090, 102, 120); standard on YHC (036, 048, 060, 072, 092, 102, 120).

Indoor Fan

The following units shall be equipped with a direct drive plenum fan design (T/YSC120E, T/YHC092,102, 120E). Plenum fan design shall include a backward-curved fan wheel along with an external rotor direct drive variable speed indoor motor. All plenum fan designs will have a variable speed adjustment potentiometer located in the control box. 3-5 ton units (standard efficiency 3-phase or high efficiency 3-phase with optional motor) are belt driven, FC centrifugal fans with adjustable motor sheaves. 3-5 ton units (1-phase or high efficiency 3-phase) have multispeed, direct drive motors. All 6-8½ ton units (standard efficiency) shall have belt drive motors with an adjustable idler-arm assembly for quick-adjustment to fan belts and motor sheaves. All motors shall be thermally protected. All 10 tons and 7½-8½ (high efficiency) have variable speed direct drive motors. All indoor fan motors meet the U.S. Energy Policy Act of 1992 (EPACT).

Outdoor Fans

The outdoor fan shall be direct-drive, statically and dynamically balanced, draw-through in the vertical discharge position. The fan motor shall be permanently lubricated and shall have built-in thermal overload protection.

Evaporator and Condenser Coils

Internally finned, 5/16" copper tubes mechanically bonded to a configured aluminum plate fin shall be standard. The microchannel type condenser coil is standard for the T/YSC 10 ton models and 7½ ton high efficiency models. The microchannel type condenser coil is not offered on the 7½ ton dehumidification model. Due to flat streamlined tubes with small ports, and metallurgical tube-to-fin bond, microchannel coil has better heat transfer performance. Microchannel condenser coil can reduce system refrigerant charge by up to 50% because of smaller internal volume, which leads to better compressor reliability. Compact all-aluminum microchannel coils also help to reduce the unit weight. All-aluminum construction improves re-cyclability. Galvanic corrosion is also minimized due to all aluminum construction. Strong aluminum brazed structure provides better fin protection. In addition, flat streamlined tubes also make microchannel coils more dust resistant and easier to clean. Coils shall be leak tested at the factory to ensure the pressure integrity. The evaporator coil and condenser coil shall be leak tested to 600 psig. The assembled unit shall be leak tested to 465 psig. The condenser coil shall have a patent pending 1+1+1 hybrid coil designed with slight gaps for ease of cleaning. A removable, reversible, double-sloped condensate drain pan with through the base condensate drain is standard.

Controls

Unit shall be completely factory-wired with necessary controls and contactor pressure lugs or terminal block for power wiring. Unit shall provide an external location for mounting a fused disconnect device. A choice of microprocessor or electromechanical controls shall be available. Microprocessor controls provide for all 24V control functions. The resident control algorithms shall make all heating, cooling, and/or ventilating decisions in response to electronic signals from sensors measuring indoor and outdoor temperatures. The control algorithm maintains accurate temperature control, minimizes drift from set point, and provides better building comfort. A centralized microprocessor shall provide anti-short cycle timing and time delay between compressors to provide a higher level of machine protection. 24-volt electromechanical control circuit shall include control transformer and contactor

High Pressure Control

All units include High Pressure Cutout as standard.

Phase monitor

Phase monitor shall provide 100% protection for motors and compressors against problems caused by phase loss, phase imbalance, and phase reversal. Phase monitor is equipped with an LED that provides an ON or FAULT indicator. There are no field adjustments. The module will automatically reset from a fault condition.

BACnet Communications

The BACnet communications interface allows the unit to communicate directly with a generic open protocol BACnet MS/TP Network Building Automation System Controls.

Refrigerant Circuits

Each refrigerant circuit offer thermal expansion valve as standard. Service pressure ports, and refrigerant line filter driers are factory-installed as standard. An area shall be provided for replacement suction line driers.

Gas Heating Section

The heating section shall have a progressive tubular heat exchanger design using stainless steel burners and corrosion resistant steel throughout. An induced draft combustion blower shall be used to pull the combustion products through the firing tubes. The heater shall use a direct spark ignition (DSI) system. On initial call for heat, the combustion blower shall purge the heat exchanger for 20 seconds before ignition. After three unsuccessful ignition attempts, the entire heating system shall be locked out until manually reset at the thermostat/zone sensor. Units shall be suitable for use with natural gas or propane (field-installed kit) and also comply with the California requirement for low NOx emissions (Gas/Electric Only).

Modulating Gas Heat

The heating section shall have a drum and tube heat exchanger design using stainless steel components. A variable speed forced combustion blower shall supply premixed fuel to a single burner ignited by a pilotless hot surface ignition system. The leaving air temperature shall be communicated to the unit controls (ReliaTel) via a discharge air sensor. This information along with the space temperature will be used to modulate the heating output.

In order to provide reliable operation, a pressure switch will require blower operation to initiate gas flow.

On an initial call for heat the combustion blower shall purge the heat exchanger 45 seconds before ignition. The heat exchanger will operate at full fire initially and then modulate down to match the desired discharge air temperature. After three unsuccessful ignition attempts, the entire heating system shall be locked out until manually reset. Units shall be suitable for use with natural gas.

Hinged Access Doors

Sheet metal hinges are available on the Filter/Evaporator, Supply Fan/Heat, and the Compressor/Control Access Doors.

Plenum Fan

The following unit shall be equipped with a direct drive plenum fan design (all 10 tons and 7.5-8.5 ton high efficiency units). Plenum fan design shall include a backward-curved fan wheel along with an external rotor direct drive variable speed indoor motor. All plenum fan designs will have a variable speed adjustment potentiometer located in the control box.

Economizer

This accessory shall be available with or without barometric relief. The assembly includes fully modulating 0-100 percent motor and dampers, minimum position setting, preset linkage, wiring harness with plug, spring return actuator and fixed dry bulb control. The barometric relief shall provide a pressure operated damper that shall be gravity closing and shall prohibit entrance of outside air during the equipment off cycle. Optional solid state or differential enthalpy control shall be available for either factory or field installation. The economizer arrives in the shipping position and shall be moved to the operating position by the installing contractor.

VAV Operation

The VFD shall receive a 0-10Vdc signal from the unit controls based upon supply static pressure and shall cause the drive to accelerate or decelerate as required to maintain the supply static pressure setpoint. When subjected to high ambient return conditions the VFD shall reduce its output frequency to maintain operation.

Through the Base Electrical Access

An electrical service entrance shall be provided allowing electrical access for both control and main power connections inside the curb and through the base of the unit. Option will allow for field installation of liquid-tight conduit and an external field-installed disconnect switch.

Through the Base Electrical with Disconnect Switch

This 3-pole, molded case, disconnect switch with provisions for through the base electrical connections are available. The disconnect switch will be installed in the unit in a water tight enclosure with access through a swinging door. Wiring will be provided from the switch to the unit high voltage terminal block. The switch will be UL/CSA agency recognized.

Note: The disconnect switch will be sized per NEC and UL guidelines but will not be used in place of unit overcurrent protection.

Accessory - Roof Curb 18" with 1" deflection vibration isolation

The roof curb shall be designed to mate with the unit's downflow supply and return and provide support and a water tight installation when installed properly. The roof curb design shall allow field fabricated rectangular supply/return ductwork to be connected directly to the curb. Curb design shall comply with NRCA requirements. Curb shall be shipped knocked down for field assembly and shall include wood nailer strips.

Accessory - Powered Exhaust

The powered exhaust shall provide exhaust of return air, when using an economizer, to maintain better building pressurization.

Unit Dimensions - 3-10 Ton R410A PKGD Unitary Gas/Electric Rooftop
Item: A1 Qty: 1 Tag(s): RTU-2

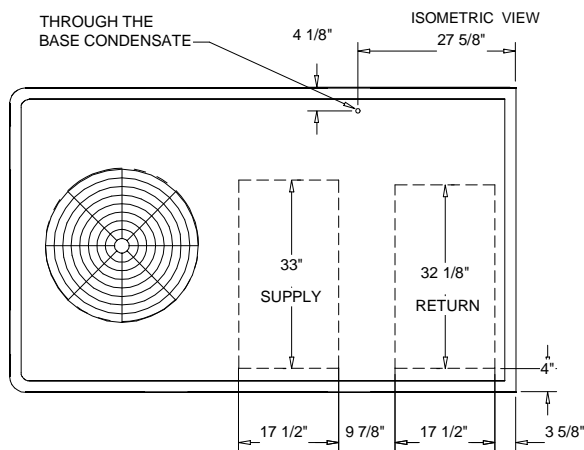
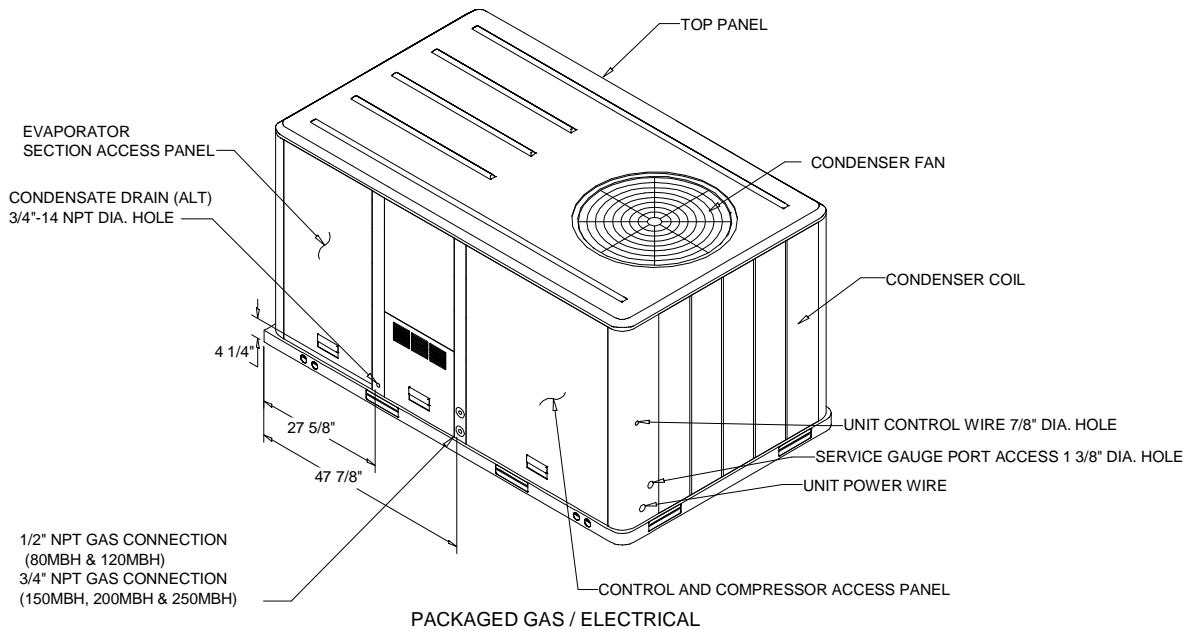

- NOTES:**
 1. THRU -THE -BASE ELECTRICAL IS NOT STANDARD ON ALL UNITS.
 2. VERIFY ALL DIMENSIONS WITH INSTALLER DOCUMENTS BEFORE INSTALLATION.

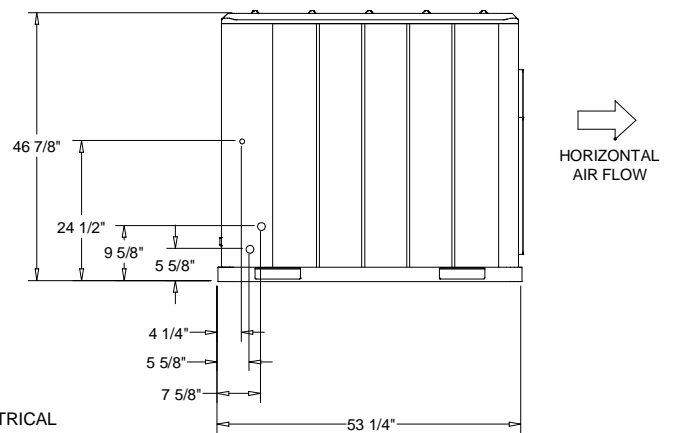
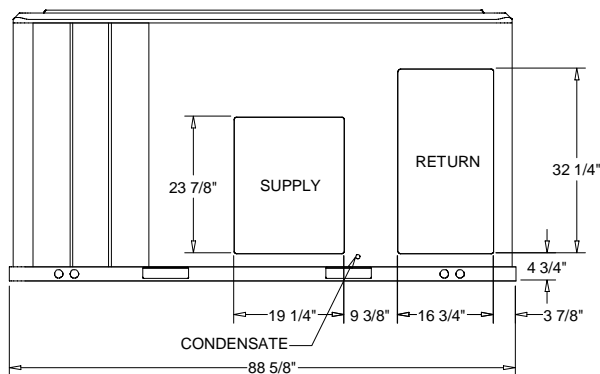

Unit Dimensions - 3-10 Ton R410A PKGD Unitary Gas/Electric Rooftop
Item: A1 Qty: 1 Tag(s): RTU-2

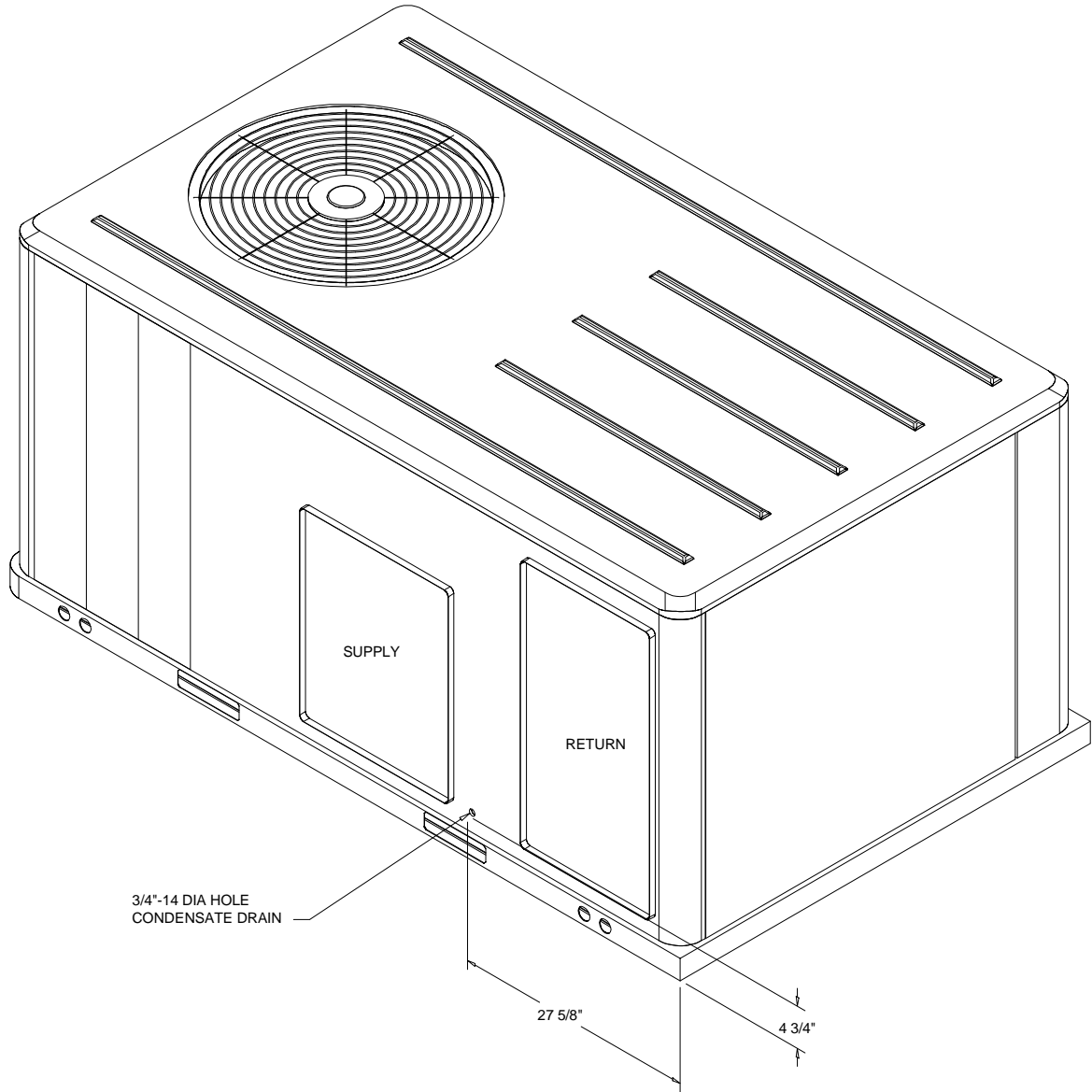

ISOMETRIC-PACKAGED COOLING

Unit Dimensions - 3-10 Ton R410A PKGD Unitary Gas/Electric Rooftop
Item: A1 Qty: 1 Tag(s): RTU-2

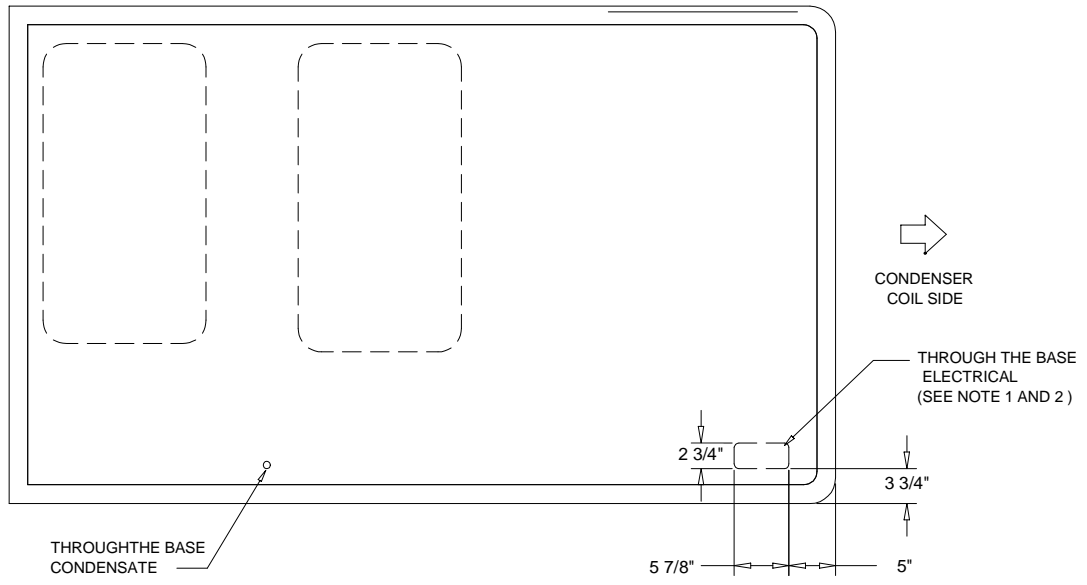
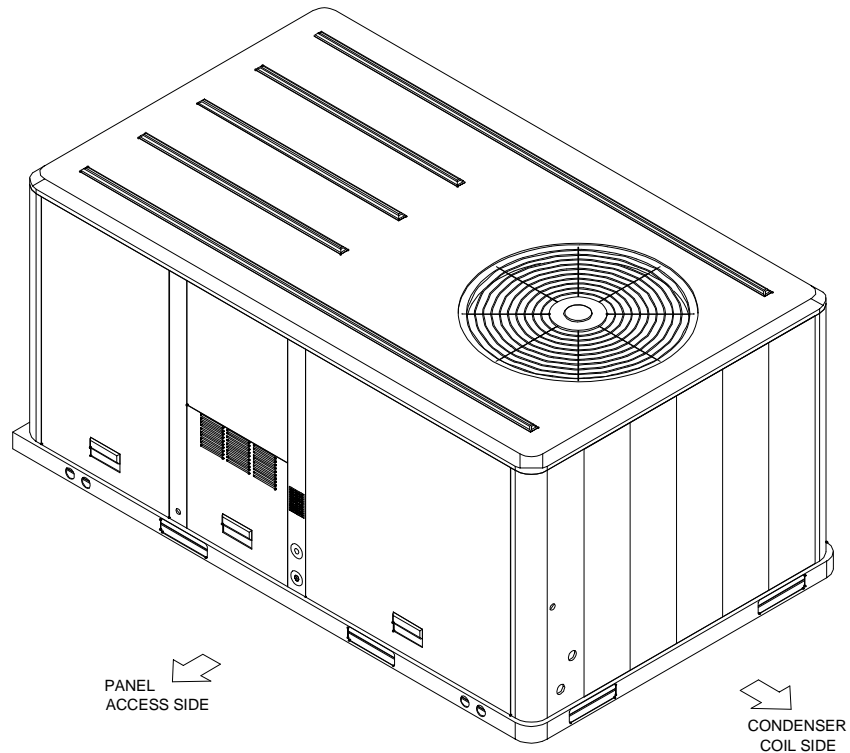

- NOTES:
1. THRU -THE -BASE GAS AND ELECTRICAL IS NOT STANDARD. VERIFY OPTION IN PRODUCT DATA IN THIS DOCUMENT.
 2. VERIFY WEIGHT, CONNECTION, OPTION CONFIGURATION AND ALL DIMENSION WITH INSTALLER DOCUMENTS BEFORE INSTALLATION

THRU THE BASE ELECTRICAL
 PLAN / ISO VIEW DRAWING

Unit Dimensions - 3-10 Ton R410A PKGD Unitary Gas/Electric Rooftop
Item: A1 Qty: 1 Tag(s): RTU-2

ELECTRICAL / GENERAL DATA

GENERAL ⁽²⁾⁽⁴⁾⁽⁶⁾ Model: YHC092F Oversized Motor Unit Operating Voltage: 517-633 Unit Primary Voltage: 575 Unit Secondary Voltage: -- Unit Hertz: 60 Unit Phase: 3 EER: 12.6 Standard Motor MCA: 15.6 MCA: N/A MFS: 20.0 MFS: N/A MCB: 20.0 MCB: N/A		HEATING PERFORMANCE HEATING - GENERAL DATA Heating Model: Medium Heating Input (BTU): 150,000/105,000 Heating Output (BTU): 120,000/84,000 No. Burners: 3 No. Stages: 2 Gas Inlet Pressure Natural Gas (Min/Max): 4.5/14 LP (Min/Max): 11.0/14.0 Gas Pipe Connection Size: 3/4"	
INDOOR MOTOR Standard Motor Oversized Motor Field Installed Oversized Motor Number: 1 Horsepower: 3.4 Motor Speed (RPM): -- Phase: 3 Full Load Amps: 3.1 Locked Rotor Amps: --		Number: 1 Horsepower: N/A Motor Speed (RPM): N/A Phase: N/A Full Load Amps: N/A Locked Rotor Amps: N/A	
COMPRESSOR Circuit 1/2 Number: 2 Horsepower: 3.8/2.4 Phase: 3 Rated Load Amps: 5.1/3.7 Locked Rotor Amps: 40.0/28.0		OUTDOOR MOTOR Number: 1 Horsepower: 0.75 Motor Speed (RPM): 1100 Phase: 1 Full Load Amps: 2.4 Locked Rotor Amps: 6.2	
POWER EXHAUST ACCESSORY ⁽³⁾ (Field Installed Power Exhaust) Phase: N/A Horsepower: N/A Motor Speed (RPM): N/A Full Load Amps: N/A Locked Rotor Amps: N/A		FILTERS Type: Throwaway Furnished: Yes Number: 4 Recommended: 20"x25"x2"	
		REFRIGERANT ⁽²⁾ Type: R-410 Factory Charge Circuit #1: 5.5 lb Circuit #2: 4.2 lb	

NOTES:

1. Maximum (HACR) Circuit Breaker sizing is for installations in the United States only.
2. Refrigerant charge is an approximate value. For a more precise value, see unit nameplate and service instructions.
3. Value does not include Power Exhaust Accessory.
4. Value includes oversized motor.
5. Value does not include Power Exhaust Accessory.
6. EER is rated at AHRI conditions and in accordance with DOE test procedures.

Weight, Clearance & Rigging Diagram - 3-10 Ton R410A PKGD Unitary Gas/Electric Rooftop
Item: A1 Qty: 1 Tag(s): RTU-2

INSTALLED ACCESSORIES NET WEIGHT DATA

ACCESSORY		WEIGHTS					
ECONOMIZER		36.0 lb					
MOTORIZED OUTSIDE AIR DAMPER							
MANUAL OUTSIDE AIR DAMPER							
BAROMETRIC RELIEF							
OVERSIZED MOTOR							
BELT DRIVE MOTOR							
POWER EXHAUST							
THROUGH THE BASE ELECTRICAL/GAS (FIOPS)		13.0 lb					
UNIT MOUNTED CIRCUIT BREAKER (FIOPS)							
UNIT MOUNTED DISCONNECT (FIOPS)		5.0 lb					
POWERED CONVENIENCE OUTLET (FIOPS)							
HINGED DOORS (FIOPS)		12.0 lb					
HAIL GUARD							
SMOKE DETECTOR, SUPPLY / RETURN							
NOVAR CONTROL							
STAINLESS STEEL HEAT EXCHANGER		6.0 lb					
REHEAT							
ROOF CURB		78.0 lb					
BASIC UNIT WEIGHTS		CORNER WEIGHTS		CENTER OF GRAVITY			
SHIPPING	NET	(A)	340.0 lb	(C)	249.0 lb	(E) LENGTH	(F) WIDTH
1124.0 lb	1026.0 lb	(B)	233.0 lb	(D)	204.0 lb	41"	23"

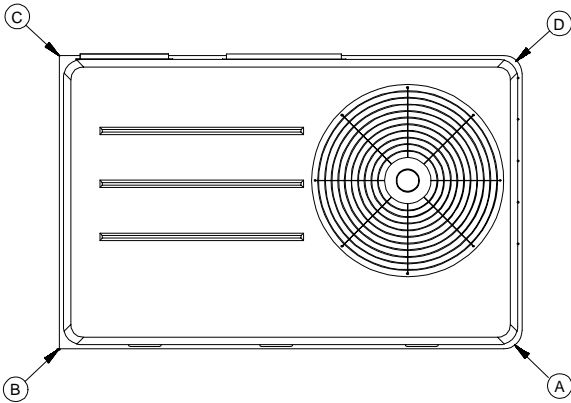

PACKAGED GAS / ELECTRICAL
CORNER WEIGHT

- NOTE:
1. CORNER WEIGHTS ARE GIVEN FOR INFORMATION ONLY.
 2. TO ESTIMATE SHIPPING WEIGHT ADD 5 LBS TO NET WEIGHT.
 3. BASIC UNIT WEIGHT DOES NOT INCLUDE ACCESSORY WEIGHT. TO OBTAIN TOTAL WEIGHT, ADD ACCESSORY NET WEIGHT TO BASIC UNIT WEIGHT.
 4. WEIGHTS FOR OPTIONS NOT LISTED ARE <5 LBS.

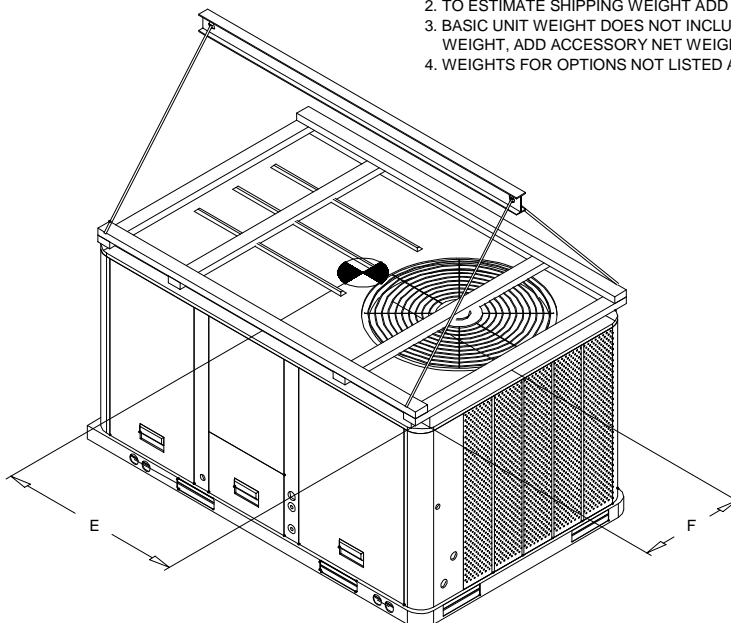

PACKAGED GAS / ELECTRICAL
RIGGING AND CENTER OF GRAVITY

Weight, Clearance & Rigging Diagram - 3-10 Ton R410A PKGD Unitary Gas/Electric Rooftop
Item: A1 Qty: 1 Tag(s): RTU-2

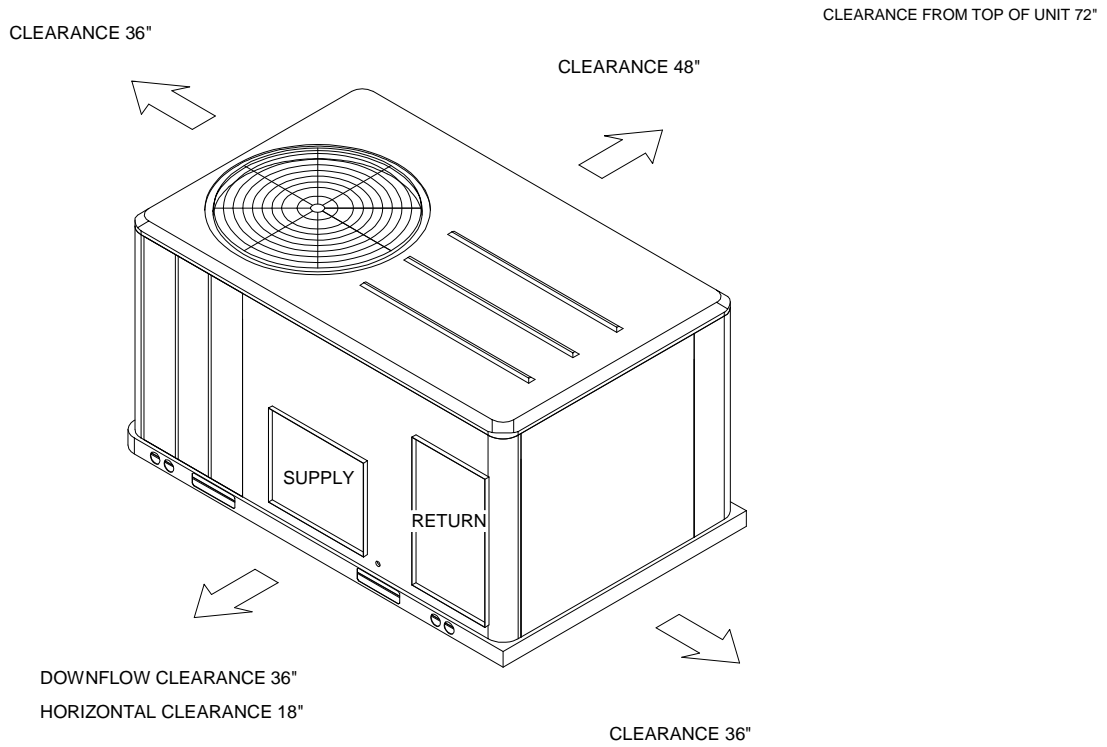

PACKAGED GAS / ELECTRIC
CLEARANCE

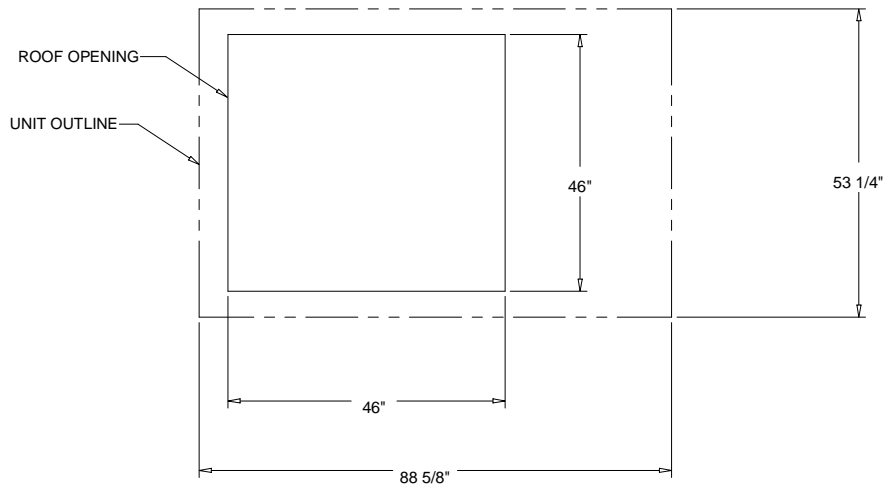

PACKAGED GAS / ELECTRIC
DOWNFLOW TYPICAL ROOF OPENING

Accessory - 3-10 Ton R410A PKGD Unitary Gas/Electric Rooftop
Item: A1 Qty: 1 Tag(s): RTU-2

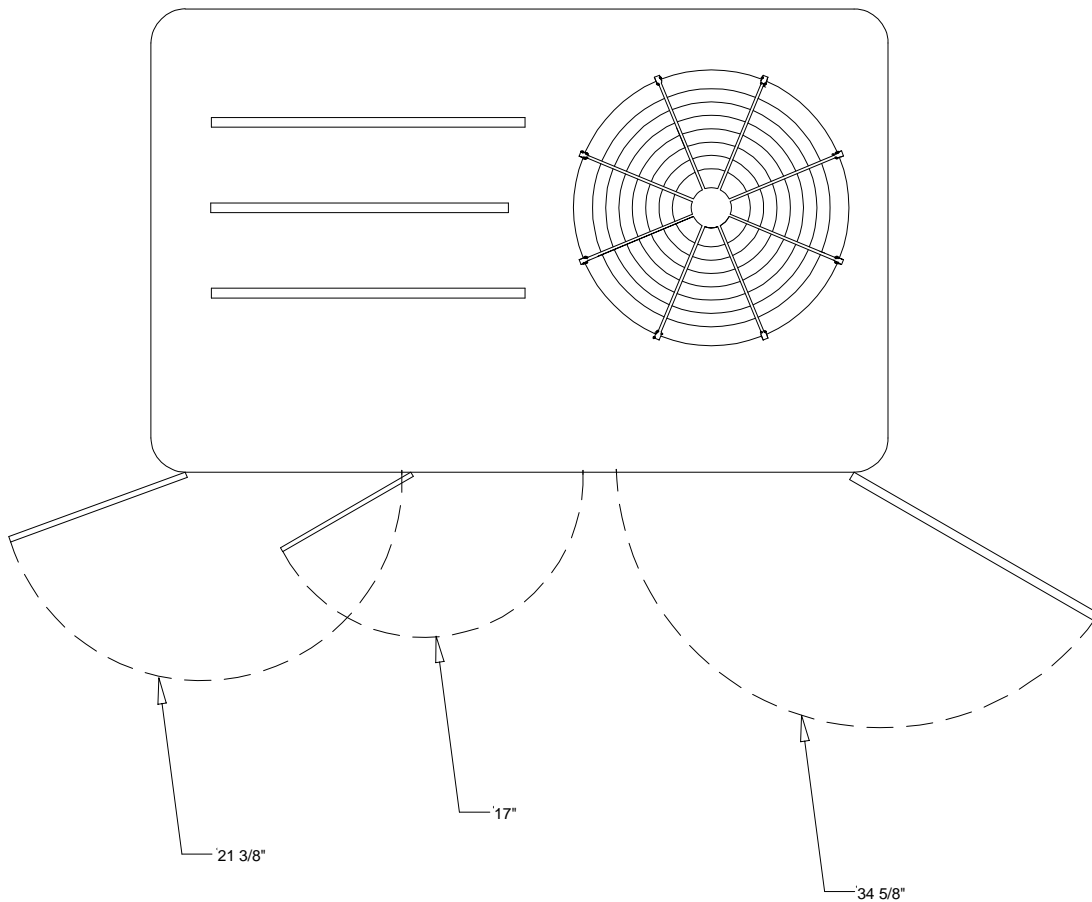

SWING DIAMETER - HINGED DOOR(S) OPTION

ACCESSORY

Accessory - 3-10 Ton R410A PKGD Unitary Gas/Electric Rooftop
Item: A1 Qty: 1 Tag(s): RTU-2

* US PATENTS 5188333, 5255887
 CANADIAN PATENT 2073900
 ADDITIONAL PATENTS PENDING

TO SUIT
TRANE
 BAYCURB043

FEATURES:

- HEAVY GAUGE GALVANIZED STEEL CONSTRUCTION
- 2 x 3" WOOD PERIMETER NAILER
- PATENTED CLIPLOCK DESIGN FOR EASE OF ASSEMBLY
- NEOPRENE GASKET

OPTIONS:

- CUSTOM OR OPTIONAL 18", AND 24" HEIGHTS
- STAINLESS STEEL OR ALUMINUM CONSTRUCTION
- INTERNAL 1" INSULATION

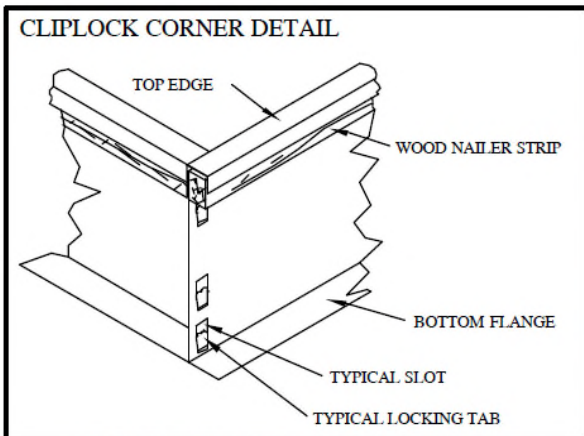

NOTE: SEE CLIPLOCK 1000 INSTALLATION INSTRUCTIONS FOR COMPLETE ASSEMBLY AND INSTALLATION PROCEDURES AND REQUIREMENTS.

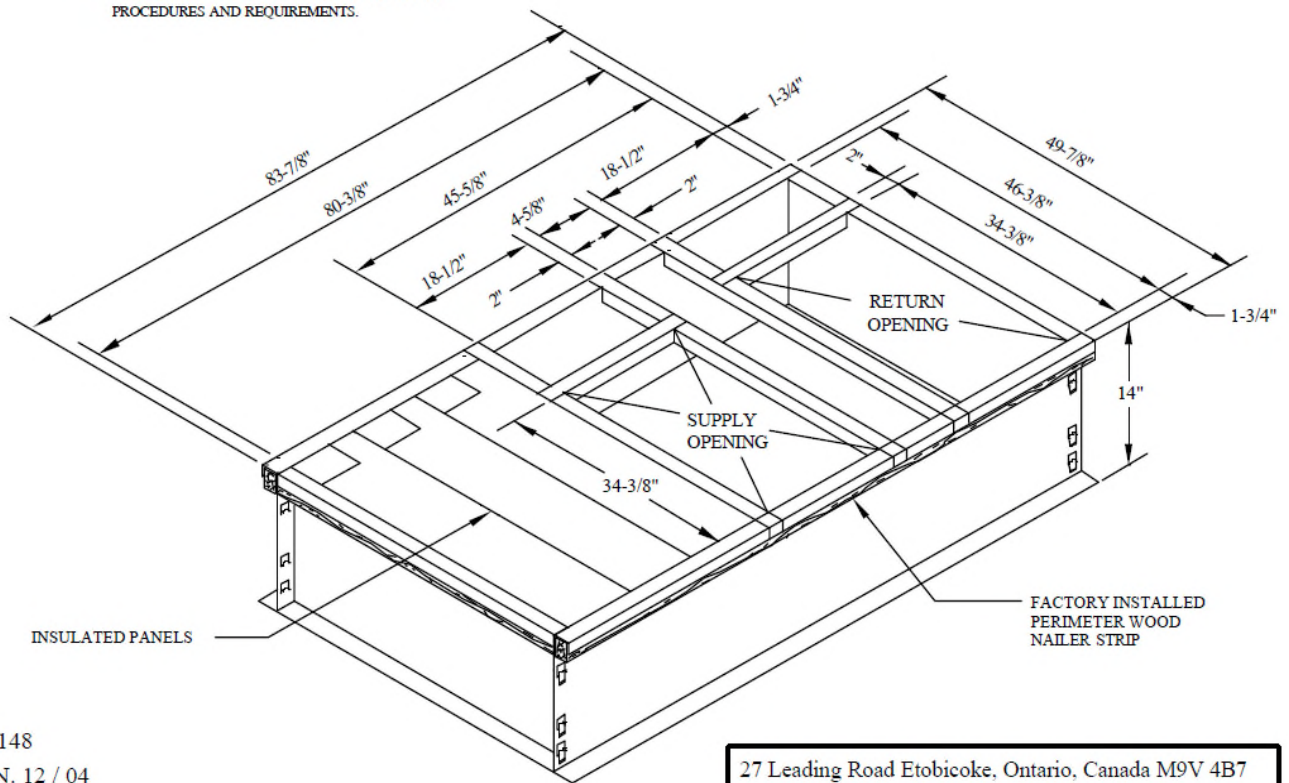

TR148
 JAN. 12 / 04

27 Leading Road Etobicoke, Ontario, Canada M9V 4B7
 TEL: (416) 742-6500 FAX: (416) 742-4251

**** Drawing shows 14" high curb but 18" curbs will be provided at site.**

Accessory - 3-10 Ton R410A PKGD Unitary Gas/Electric Rooftop
Item: A1 Qty: 1 Tag(s): RTU-2

FEATURES:

- DESIGNED TO FIT ON STANDARD CURBS
- ONE PIECE FULLY ASSEMBLED CONSTRUCTION
- HEAVY GAUGE STEEL
- MITERED CORNERS, CONTINUOUSLY WELDED TO GUARD AGAINST WATER LEAKAGE
- FLEXIBLE NON-ABRASIVE WEATHER SEAL
- FREE STANDING 1" DEFLECTION SPRINGS WITH LACQUER BASED POLY-VYNYL FINISH
- NEOPRENE COVERED NON-SKID SPRING BASE PLATE WITH RAISED ACOUSTICAL CUP
- SUPPLY AND RETURN AIR OPENING FLEX CONNECTORS

CAUTION:
 THIS ACCESSARY MAY REQUIRE RE-ENGINEERING IF POWER EXHAUST IS UTILIZED.

ALL OR A PORTION OF THE COMPONENTS CONTAINED ON THIS DRAWING MAY BE PROTECTED BY PATENT NUMBERS 5188333, 5255887, 2073900.

TRANE
BAYCURB043

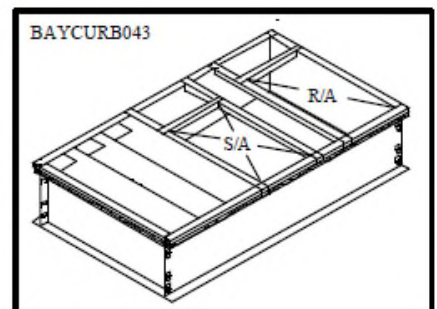
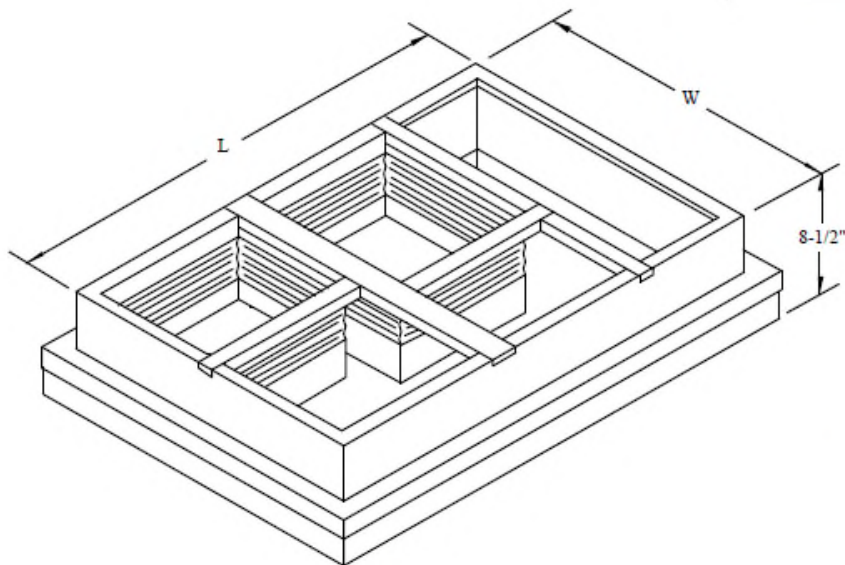
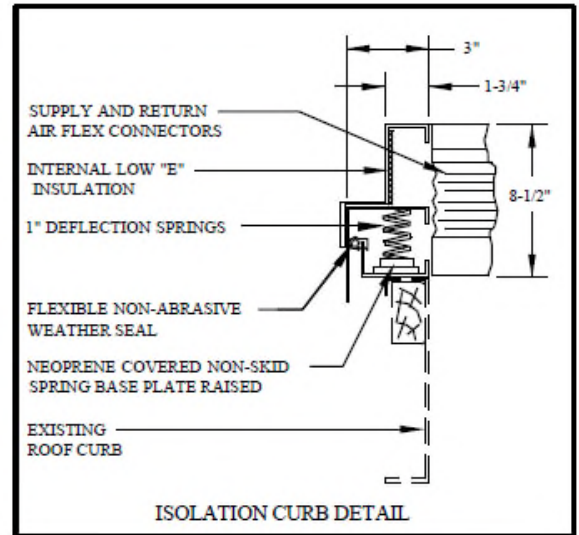

MODEL	USE WITH	L	W
BAYCURB043	PRESEDENT SERIES	83-7/8"	49-7/8"

Accessory - 3-10 Ton R410A PKGD Unitary Gas/Electric Rooftop
Item: A1 Qty: 1 Tag(s): RTU-2

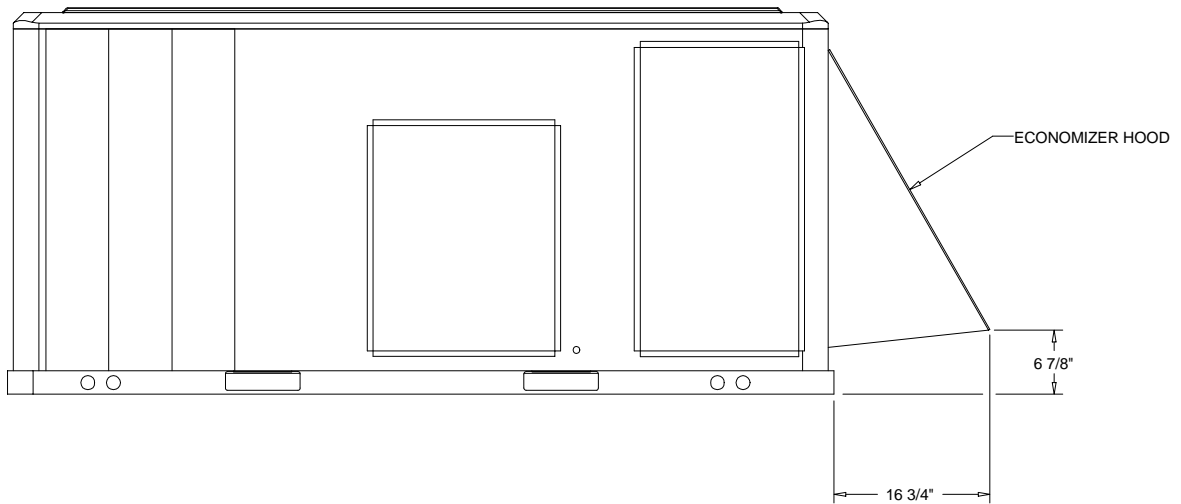
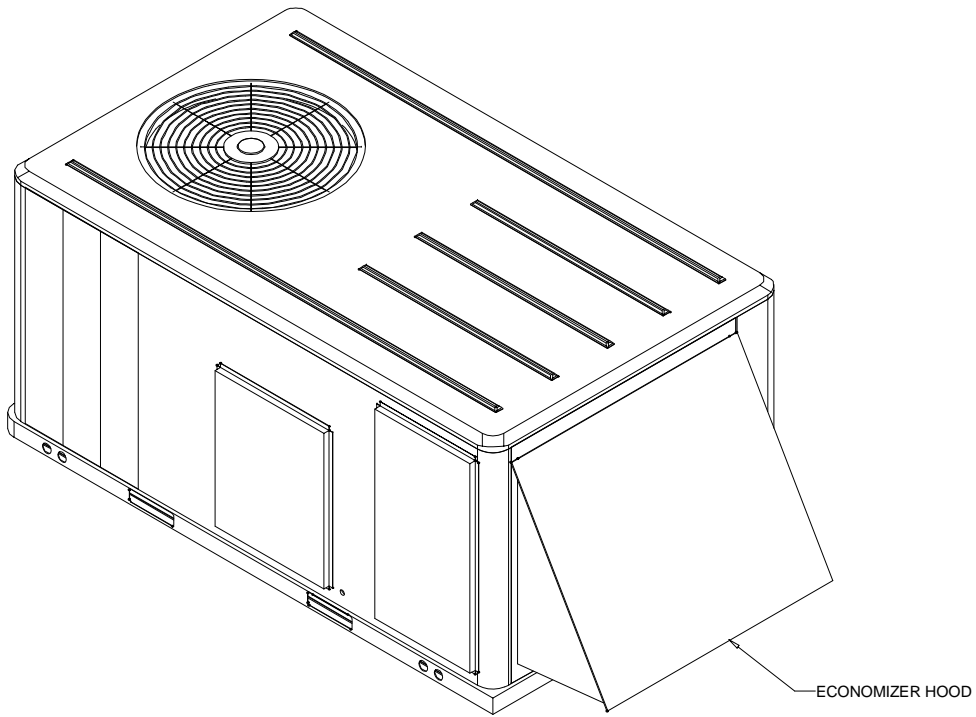

ACCESSORY - ECONOMIZER HOOD

Accessory - 3-10 Ton R410A PKGD Unitary Gas/Electric Rooftop
 Item: A1 Qty: 1 Tag(s): RTU-2

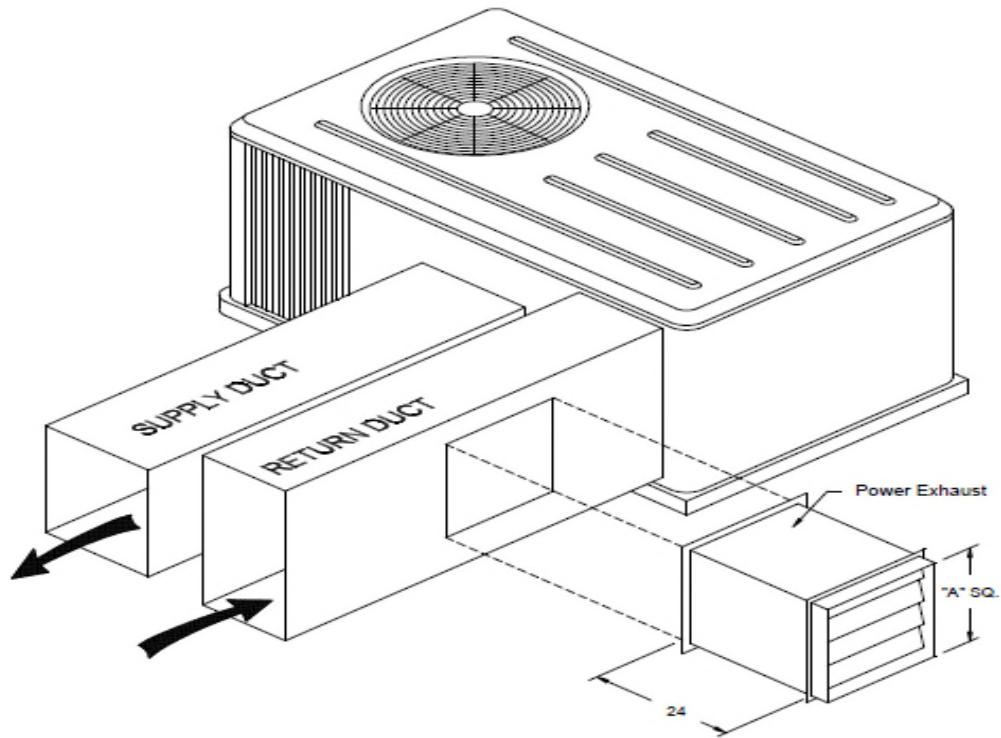

Power exhaust must be field wired and installed.

40% Power Exhaust	100% Power Exhaust	ThyCurb	A	Size	HP	PH	CFM@1/4" S.P.	Qty.	Tag
T/W/YSC, T/W/YHC 038E		TR5PE0400-3	16	12	1/3	3	400		
T/W/YSC, T/W/YHC 048E		TR5PE0640-3	16	12	1/3	3	640		
T/W/YSC, T/W/YHC 060E		TR5PE0800-3	16	12	1/3	3	800		
T/W/YSC, T/YHC 072E, T/W/YSC 090E, T/YSC, T/YHC 092E	T/W/YSC, T/W/YHC 036E	TR5PE1200-3	16	12	1/4	3	1200		
T/YSC, T/YHC 102E T/W/YSC, T/YHC 120E	T/W/YSC, T/W/YHC 048E	TR5PE1600-3	18	14	1/4	3	1600		
	T/W/YSC, T/W/YHC 060E	TR5PE2000-3	20	16	1/3	3	2000		
	T/W/YSC, T/YHC 072E	TR5PE2500-3	22	18	1/2	3	2500	1	2701CFM
	T/W/YSC 090E, 092E	TR5PE3000-3	22	18	1/2	3	3000		
	T/YSC, T/YHC 102E	TR5PE3400-3	24	20	1/2	3	3400		
	T/W/YSC, T/YHC 120E	TR5PE4000-3	24	20	3/4	3	4000		

Accessory - 3-10 Ton R410A PKGD Unitary Gas/Electric Rooftop
Item: A1 Qty: 1 Tag(s): RTU-2

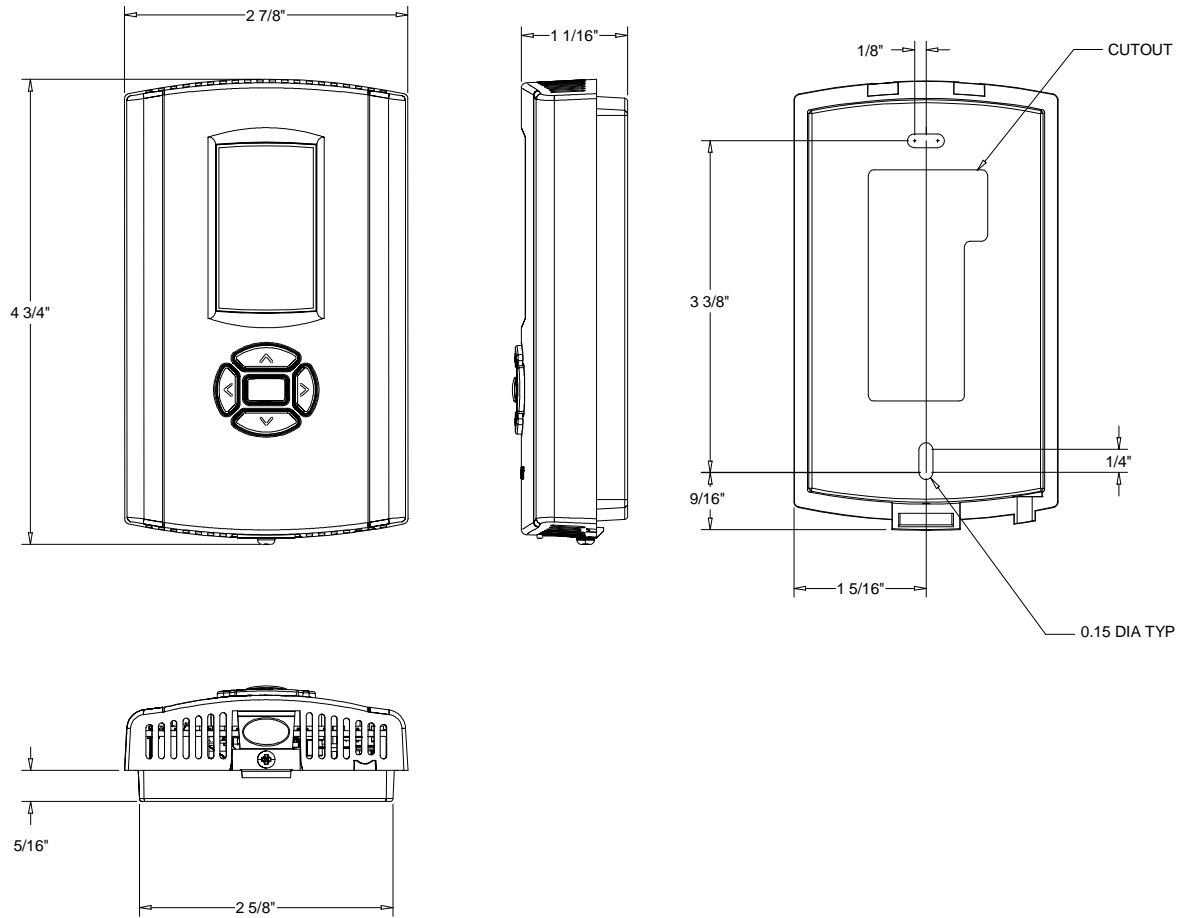

BAYSEN135 - ZONE SENSOR
DIGITAL LCD

Tag Data - Packaged Gas/Electric Rooftop Units (Qty: 3)

Item	Tag(s)	Qty	Description	Model Number
B1	RTU-1	1	12 1/2 Ton Packaged Unitary Gas/Elec.	YHD150GWRVA--
B2	RTU-3	1	12 1/2 Ton Packaged Unitary Gas/Elec.	YHH150GWRVA--
B3	RTU-4	1	12 1/2 Ton Packaged Unitary Gas/Elec.	YHH150GWRVA--

Product Data - Packaged Gas/Electric Rooftop Units**All Units**

Gas/Electric
 High efficiency
 Downflow for RTU-1 only
 Horizontal for RTU-3 & RTU-4 only
 12.5 Ton
 575/60/3
 Reliatel
 Gas Heat – Modulating (5:1 Turndown ratio)
 Stainless steel heat exchanger
 0-100% Economizer, dry bulb control (Field)
 Comparative enthalpy kit (Field)
 VAV standard motor for RTU-1 & RTU-3 only
 Discharge Air Sensing Tube (Field) for RTU-1 & RTU-3 only
 Froststat (Field) for RTU-1 & RTU-3 only
 Hinged panels/2" Pleated Filters Merv 8
 Through the base electric
 Unit mounted non-fused disconnect
 BACnet communications interface
 Special Roof curb with 1" deflection vibration isolation (Field)
 Power exhaust – Unit mounted (Field) for RTU-1 only
 Barometric relief damper – Duct mounted (Field) for RTU-3 & RTU-4 only
 Digital display zone sensor (Field)

Performance Data - Packaged Gas/Electric Rooftop Units

Tags	RTU-1	RTU-3	RTU-4
Design Airflow (cfm)	4500	4400	4500
Cooling Entering Dry Bulb (F)	81.67	78.00	78.00
Cooling Entering Wet Bulb (F)	67.46	64.00	64.00
Ent Air Rel Humidity (%)	48.17	46.60	46.60
Ambient Temp (F)	95.00	95.00	95.00
Cooling Leaving Unit DB (F)	59.60	55.58	55.63
Cooling Leaving Unit WB (F)	57.44	53.37	53.48
Gross Total Capacity (MBh)	151.87	143.90	144.61
Gross Sensible Capacity (MBh)	118.35	115.17	116.21
Gross Latent Capacity (MBh)	33.52	28.74	28.40
Net Total Capacity (MBh)	142.73	137.81	139.65
Net Sensible Capacity (MBh)	109.21	109.07	111.25
Heating LAT (F)	58.17	59.49	58.17
Heating Temp Rise (F)	58.17	59.49	58.17
Input Htg Capacity (MBh)	350.00	350.00	350.00
Output Htg Capacity (MBh)	284.00	284.00	284.00
Output Htg Capacity w/Fan (MBh)	293.14	290.10	288.96
Design ESP (in H2O)	1.498	0.996	0.751
Component SP Add (in H2O)	0.020	0.020	0.020
Indoor Mtr. Operating Power (bhp)	2.90	1.94	1.57
Indoor RPM (rpm)	798	671	606
Indoor Motor Power (kW)	2.16	1.44	1.17
Outdoor Motor Power (kW)	0.86	0.86	0.86
Compressor Power (kW)	10.11	10.04	10.04
System Power (kW)	13.13	12.34	12.08
IPLV @ AHRI (IPLV)	14.2	14.2	12.6

Tags	RTU-1	RTU-3	RTU-4
MCA (A)	25.00	25.00	25.00
MOP (A)	30.00	30.00	30.00
Compressor 1 RLA (A)	9.60	9.60	9.60
Compressor 2 RLA (A)	6.00	6.00	6.00
Condenser Fan FLA (A)	1.30	1.30	1.30
Evaporator Fan FLA (A)	3.90	3.90	3.90
Min. Unit Operating Weight (lb)	1958.0	1958.0	1933.0
Max Unit Operating Weight (lb)	2360.0	2360.0	2335.0
Fan Motor Heat (MBh)	9.14	6.10	4.96
Evap Coil Leav Air Temp (DB) (F)	57.32	53.76	54.09
Evap Coil Leav Air Temp (WB) (F)	56.55	52.61	52.83
Dew Point Temp (F)	56.06	51.75	51.90
Rated capacity (AHRI) (MBh)	140.00	140.00	140.00
Exhaust fan power (kW)	0.56	0.56	0.56
Refrig charge (HFC-410A) - ckt 1 (lb)	8.4	8.4	8.4
Refrig charge (HFC-410A) - ckt 2 (lb)	5.8	5.8	5.8
ASHRAE 90.1	Yes	Yes	Yes
Saturated Suction Temp Circuit 1 (F)	52.59	49.07	49.39
Saturated Discharge Temp Circuit 1 (F)	115.33	114.70	114.74
Saturated Suction Temp Circuit 2 (F)	52.52	49.04	49.36
Saturated Discharge Temp Circuit 2 (F)	112.17	111.59	111.65
EER @ AHRI Conditions (EER)	12.1	12.1	12.1
Total Static Pressure (in H2O)	1.518	1.016	0.771

Mechanical Specifications - Packaged Gas/Electric Rooftop Units**Item: B1 - B3 Qty: 3 Tag(s): RTU-1, RTU-3, RTU-4****General**

The units shall be dedicated downflow or horizontal airflow. The operating range shall be between 115°F and 0°F in cooling as standard from the factory for all units. Cooling performance shall be rated in accordance with AHRI testing procedures. All units shall be factory assembled, internally wired, fully charged with R-410A, and 100 percent run tested to check cooling operation, fan and blower rotation and control sequence, before leaving the factory. Wiring internal to the unit shall be colored and numbered for simplified identification. Units shall be UL listed and labeled, classified in accordance to UL 1995/C 22.2, 236-05 3rd Edition.

Casing

Unit casing shall be constructed of zinc coated, heavy gauge, galvanized steel. Exterior surfaces shall be cleaned, phosphatized, and finished with a weather-resistant baked enamel finish. Unit's surface shall be tested 672 hours in a salt spray test in compliance with ASTM B117. Cabinet construction shall allow for all maintenance on one side of the unit. In order to ensure a water and air tight seal, service panels shall have lifting handles and no more than three screws to remove. All exposed vertical panels and top covers in the indoor air section shall be insulated with a 1/2 inch, 1 pound density foil-faced, fire-resistant, permanent, odorless, glass fiber material. The base of the downflow unit shall be insulated with 1/2 inch, 1 pound density foil-faced, closed-cell material. The downflow unit's base pan shall have no penetrations within the perimeter of the curb other than the raised 11/8 inch high supply/return openings to provide an added water integrity precaution, if the condensate drain backs up. The base of the unit shall have provisions for forklift and crane lifting.

Unit Top

The top cover shall be one piece, or where seams exist, double hemmed and gasket sealed to prevent water leakage.

Filters

Two inch pleated media filters shall be available.

Compressors

All units shall have direct-drive, hermetic, scroll type compressors with centrifugal type oil pumps. Motor shall be suction gas-cooled and shall have a voltage utilization range of plus or minus 10 percent of nameplate voltage. Internal overloads shall be provided with the scroll compressors. All models shall have crankcase heaters, phase monitors and low and high pressure control as standard.

Crankcase Heaters

These band heaters provide improved compressor reliability by warming the oil to prevent migration during off-cycles or low ambient conditions. These are standard on all Voyager models.

Refrigerant Circuits

Each refrigerant circuit shall have independent fixed orifice or thermostatic expansion devices, service pressure ports, and refrigerant line filter driers factory installed as standard. An area shall be provided for replacement suction line driers.

Evaporator and Condenser Coils

Microchannel coils will be burst tested by the manufacturer. Internally finned, 5/16" copper tubes mechanically bonded to a configured aluminum plate fin shall be standard for evaporator coils. Microchannel condenser coils shall be standard on all units. Coils shall be leak tested to ensure the pressure integrity. The evaporator coil and condenser coil shall be leak tested to 225 psig and pressure tested to 450 psig. Sloped condensate drain pans are standard.

Gas Heating Section

The heating section shall have a drum and tube heat exchanger design using corrosion resistant steel components. A forced combustion blower shall supply premixed fuel to a single burner ignited by a pilotless hot surface ignition system. In order to provide reliable operation, a negative pressure gas valve shall be used on standard furnaces and a pressure switch on furnaces with modulating heat that requires blower operation to initiate gas flow. On an initial call for heat, the combustion blower shall purge the heat exchanger 45 seconds before ignition. After three unsuccessful ignition attempts, the entire heating system shall be locked out until manually reset at the thermostat. Units shall be suitable for use with natural gas or propane (field installed kit) and shall also comply with California requirements for low NOx emissions. The 12½- 25 tons shall have two stage heating (Gas/Electric Only).

Modulating Gas Heat

The heating section shall have a drum and tube heat exchanger design using stainless steel components. A variable speed forced combustion blower shall supply premixed fuel to a single burner ignited by a pilotless hot surface ignition system. The leaving air temperature shall be communicated to the unit controls (ReliaTel) via a discharge air sensor. This information along with the space temperature will be used to modulate the heating output.

In order to provide reliable operation, a pressure switch will require blower operation to initiate gas flow.

On an initial call for heat the combustion blower shall purge the heat exchanger 45 seconds before ignition. The heat exchanger will operate at full fire initially and then modulate down to match the desired discharge air temperature. After three unsuccessful ignition attempts, the entire heating system shall be locked out until manually reset.

Units shall be suitable for use with natural gas.

Outdoor Fans

The outdoor fan shall be direct-drive, statically and dynamically balanced, draw-through in the vertical discharge position. The fan motor(s) shall be permanently lubricated and shall have built-in thermal overload protection.

Indoor Fan

Units above shall have belt driven, FC centrifugal fans with adjustable motor sheaves. Units with standard motors shall have an adjustable idler-arm assembly for quick-adjustment of fan belts and motor sheaves. All motors shall be thermally protected. Oversized motors shall be available for high static application. All indoor fan motors meet the U.S. Energy Policy Act of 1992 (EPACT).

Controls

Unit shall be completely factory wired with necessary controls and contactor pressure lugs or terminal block for power wiring. Unit shall provide an external location for mounting a fused disconnect device. ReliaTel controls shall be provided for all 24 volt control functions. The resident control algorithms shall make all heating, cooling, and/or ventilating decisions in response to electronic signals from sensors measuring indoor and outdoor temperatures. The control algorithm maintains accurate temperature control, minimizes drift from set point, and provides better building comfort. A centralized control shall provide anti-short cycle timing and time delay between compressors to provide a higher level of machine protection.

High Pressure Cutout

This option is offered for units that do not have High Pressure cutout as standard.

Discharge Line Thermostat

A bi-metal element discharge line thermostat is installed as a standard option on the discharge line of each system. This standard option provides extra protection to the compressors against high discharge temperatures in case of loss of charge, extremely high ambient and other conditions which could drive the discharge temperature higher. Discharge line thermostat is wired in series with high pressure control. When the discharge temperature rises above the protection limit, the bi-metal disc in the thermostat switches to the off position, opening the 24 VAC circuit. When the temperature on the discharge line cools down, the bi-metal disc closes the contactor circuit, providing power to the compressor. When the thermostat opens the fourth time, the ReliaTel control must be manually reset to resume operation on that stage.

Through the Base Electrical with Disconnect Switch

Three-pole, molded case, disconnect switch with provisions for through the base electrical connections are available. The disconnect switch will be installed in the unit in a water tight RT-PRC028-EN 121 enclosure with access through a swinging door. Factory wiring will be provided from the switch to the unit high voltage terminal block. The switch will be UL/CSA agency recognized.

Note: The disconnect switch will be sized per NEC and UL guidelines but will not be used in place of unit overcurrent protection.

Hinged Access Doors

Sheet metal hinges are available on the Filter/Evaporator Access Door and the Compressor/Control Access Door. This option is available on all downflow models.

BACnet Communications

The BACnet communications interface allows the unit to communicate directly with a generic open protocol BACnet MS/TP Network Building Automation System Controls.

Comparative Enthalpy-Factory Installed

This option will be factory installed to measure and communicate humidity for both outdoor and return air conditions, and return air temperature. The unit will receive and use this information to maximize use of economizer cooling, and to provide maximum occupant comfort control.

Accessory - Economizer – Downflow (RTU-1 ONLY)

The assembly includes fully modulating 0-100 percent motor and dampers, minimum position setting; preset linkage, wiring harness with plug, fixed dry bulb and spring return actuator.

Accessory - Powered Exhaust (RTU-1 ONLY)

The powered exhaust shall provide exhaust of return air, when using an economizer, to maintain better building pressurization.

Accessory - Economizer – Horizontal (RTU-3, RTU-4 ONLY)

The horizontal economizer shall contain the same features as the downflow economizer with the exception of barometric relief to be installed in the duct and NOT unit mounted.

Accessory – RA Duct Mounted Barometric Relief Damper (RTU-3, RTU-4 ONLY)

The barometric relief damper shall be mounted in the return air duct and shall provide a pressure operated damper that shall be gravity closing and shall prohibit entrance of outside air during the equipment "off" cycle.

Accessory - Roof Curb 18" with 1" deflection vibration isolation – Downflow (RTU-1 ONLY) rest Horizontal

The roof curb shall be designed to mate with the downflow unit and provide support and a water tight installation when installed properly. The roof curb design shall allow field-fabricated rectangular supply/return ductwork to be connected directly to the curb. Curb design shall comply with NRCA requirements. Curb shall be shipped knocked down for field assembly and shall include wood nailer strips.

Accessory - Digital Display Zone Sensor

The Digital LCD (Liquid Crystal Display) zone sensor has the look and functionality of standard zone sensors. This sensor includes a digital display of set point adjustment and space temperature in F (Fahrenheit) or C (Celsius). Includes FAN and SYSTEM buttons (supports the service functions of the standard sensor). E-squared memory stores last programmed set points. Requires 24 VAC (Volts AC). This sensor should be utilized with ReliaTel₂ controls.

VAV Operation (RTU-1 & RTU-3 ONLY)

The VFD shall receive a 0-10 Vdc signal from the unit controls based upon supply static pressure and shall cause the drive to accelerate or decelerate as required to maintain the supply static pressure setpoint. When subjected to high ambient return conditions the VFD shall reduce its output frequency to maintain operation.

Hinged Access Doors - Ultra High

Sheet metal hinges are available on the Filter/Evaporator Access Door and the Compressor/Control Access Door. This option is available on all downflow models.

Unit Dimensions - Packaged Gas/Electric Rooftop Units

Item: B1 Qty: 1 Tag(s): RTU-1

NOTES:

1. GAS CONNECTION PIPE SIZE 3/4"
2. THRU -THE -BASE GAS AND ELECTRICAL IS NOT STANDARD ON ALL UNITS. (SELECTED OPTION: SEE ACCESSORY SHEET)
3. VERIFY WEIGHT, CONNECTION, AND ALL DIMENSION WITH INSTALLER DOCUMENTS BEFORE INSTALLATION

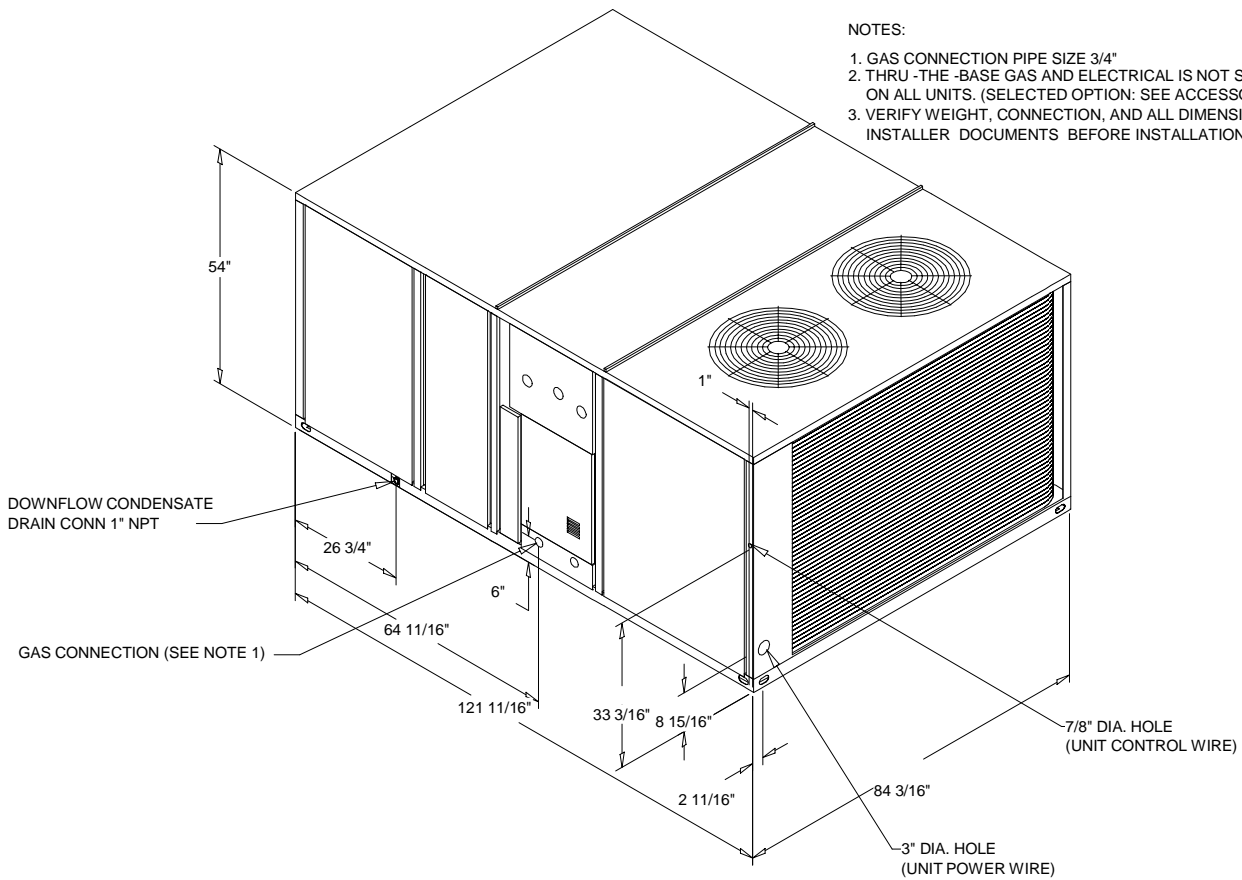

PACKAGED GAS/ELECTRIC - DOWNFLOW
ISOMETRIC DRAWING

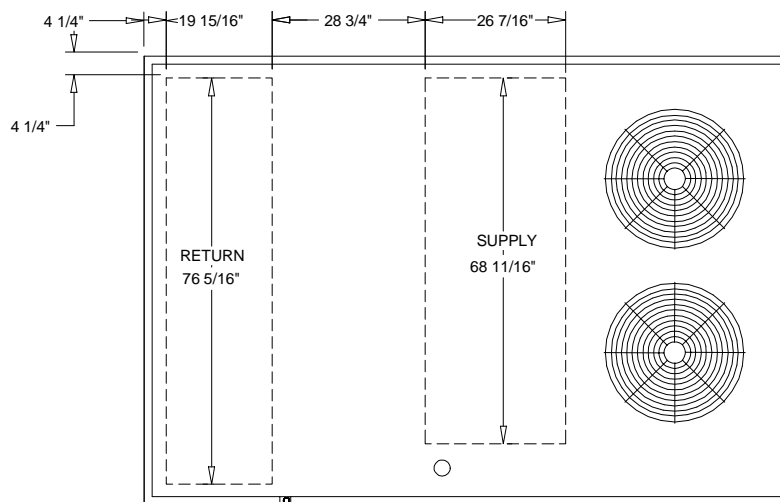

PACKAGED GAS/ELECTRIC - DOWNFLOW
PLAN VIEW DRAWING

Unit Dimensions - Packaged Gas/Electric Rooftop Units

Item: B1 Qty: 1 Tag(s): RTU-1

ELECTRICAL / GENERAL DATA

<p>GENERAL PERFORMANCE</p> <p>Model (Ton): YHD150G (12.5)</p> <p>Unit Operating Voltage Range: 517-633</p> <p>Unit Primary Voltage: 575</p> <p>Unit Secondary Voltage: -</p> <p>Unit Hertz: 60</p> <p>Unit Phase: 3</p> <p>EER: ⁽⁵⁾ 12.1</p>			<p>Standard Motor ^{(1) (3)}</p> <p>Minimum Circuit Ampacity: 25.0</p> <p>Maximum Fuse Size: 30.0</p> <p>Maximum (HACR) Circuit Breaker: 30.0</p>						
<p>Standard Oversized Motor ^{(1) (4)}</p> <p>Minimum Circuit Ampacity: -</p> <p>Maximum Fuse Size: -</p> <p>Maximum (HACR) Circuit Breaker: -</p>			<p>Accessory Oversized Motor ^{(1) (4)}</p> <p>Minimum Circuit Ampacity: -</p> <p>Maximum Fuse Size: -</p> <p>Maximum (HACR) Circuit Breaker: -</p>						
<p>GAS HEATING</p> <p>Heating Models: Modulating</p> <p>Heating and 1 Stage Input (Btu/h): 350,000 / 70,000</p> <p>Heating and 1 Stage Output (Btu/h): 283,000 / 56,700</p> <p>Min./Max. Gas Input - Pressure Natural or LP (in w.c): 2.5/14.0</p> <p>Gas Connection Pipe Size: 3/4"</p>		<p>COMPRESSOR</p> <p>Circuit(s)</p> <p>Number: 2</p> <p>Horsepower: 5.6/3.67</p> <p>Phase: 3</p> <p>Rated Load Amps: 9.6/6.0</p> <p>Locked Rotor Amps: 78.0/41.0</p>							
<p>INDOOR MOTOR</p> <p>Standard Motor</p> <p>Number: ⁽³⁾ 1</p> <p>Horsepower: 3.0</p> <p>Motor Speed (RPM): 1,740</p> <p>Phase: 3</p> <p>Full Load Amps: 3.9</p> <p>Locked Rotor Amps: 31.0</p>						<p>Standard Oversized Motor ⁽⁴⁾</p> <p>Number: -</p> <p>Horsepower: -</p> <p>Motor Speed (RPM): -</p> <p>Phase: -</p> <p>Full Load Amps: -</p> <p>Locked Rotor Amps: -</p>		<p>Accessory Oversized Motor ⁽⁴⁾</p> <p>Number: -</p> <p>Horsepower: -</p> <p>Motor Speed (RPM): -</p> <p>Phase: -</p> <p>Full Load Amps: -</p> <p>Locked Rotor Amps: -</p>	
<p>OUTDOOR MOTOR</p> <p>Number: 1</p> <p>Horsepower: 0.5</p> <p>Motor speed (RPM): 1,100</p> <p>Phase: 1</p> <p>Full Load Amps: 1.3</p> <p>Locked Rotor Amps: 3.2</p>		<p>POWER EXHAUST (Field Installed Power Exhaust)</p> <p>Horsepower: 0.75</p> <p>Motor Speed (RPM): 1,040</p> <p>Phase: 1</p> <p>Full Load Amps: 2.1</p> <p>Locked Rotor Amps: 5.2</p>		<p>COMBUSTION BLOWER MOTOR (Gas-Fired Heating only)</p> <p>Horsepower: -</p> <p>Motor Speed (RPM): -</p> <p>Phase: -</p> <p>Full Load Amps: -</p> <p>Locked Rotor Amps: -</p>					
<p>FILTER</p> <p>Type: Throwaway</p> <p>Furnished: Yes</p> <p>Number: 4/4</p> <p>Recommended Size: 20"x20"x2" / 20"x25"x2"</p>			<p>REFRIGERANT ⁽²⁾</p> <p>Circuit #1 / 2</p> <p>Type: R - 410</p> <p>Factory Charge</p> <p>Circuit #1 / 2: 8.4 lb / 5.8 lb</p>						

NOTES:

1. Maximum (HACR) Circuit Breaker sizing is for installations in the United States only.
2. Refrigerant charge is an approximate value. For a more precise value, see unit nameplate and service instructions.
3. Value include Standard Motor.
4. Value include Oversized Motor
5. EER is rated at AHRI conditions and in accordance with DOE test procedures.

Unit Dimensions - Packaged Gas/Electric Rooftop Units
Item: B2, B3 Qty: 2 Tag(s): RTU-3, RTU-4

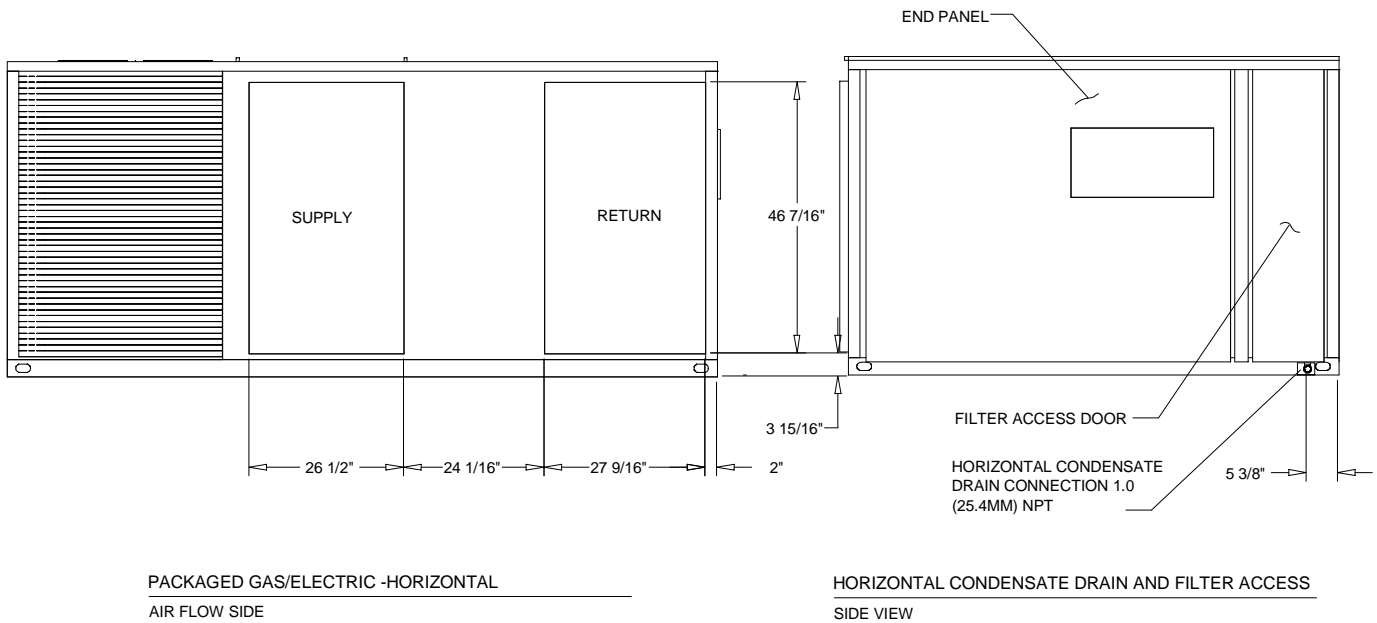
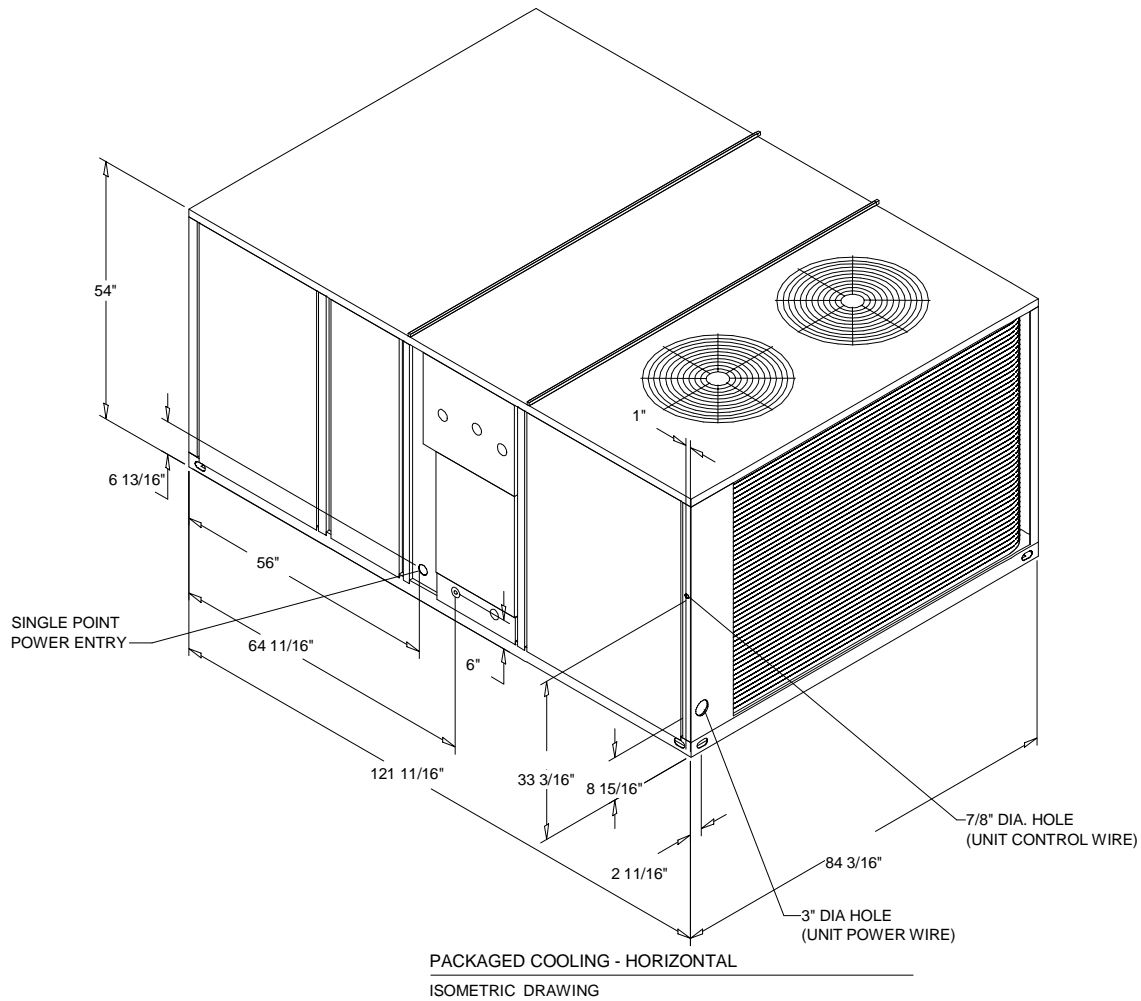

Unit Dimensions - Packaged Gas/Electric Rooftop Units
Item: B2, B3 Qty: 2 Tag(s): RTU-3, RTU-4

ELECTRICAL / GENERAL DATA

<p>GENERAL PERFORMANCE</p> <p>Model (Ton): YHH150 (12.5)</p> <p>Unit Operating Voltage Range: 517-633</p> <p>Unit Primary Voltage: 575</p> <p>Unit Secondary Voltage: -</p> <p>Unit Hertz: 60</p> <p>Unit Phase: 3</p> <p>EER: ⁽⁵⁾ 12.1</p>			<p>Standard Motor ^{(1) (3)}</p> <p>Minimum Circuit Ampacity: 25.0</p> <p>Maximum Fuse Size: 30.0</p> <p>Maximum (HACR) Circuit Breaker: 30.0</p>				
			<p>Standard Oversized Motor ^{(1) (4)}</p> <p>Minimum Circuit Ampacity: -</p> <p>Maximum Fuse Size: -</p> <p>Maximum (HACR) Circuit Breaker: -</p>		<p>Accessory Oversized Motor ^{(1) (4)}</p> <p>Minimum Circuit Ampacity: -</p> <p>Maximum Fuse Size: -</p> <p>Maximum (HACR) Circuit Breaker: -</p>		
<p>GAS HEATING</p> <p>Heating Models: Modulating</p> <p>Heating and 1 Stage Input (Btu/h): 350,000 / 70,000</p> <p>Heating and 1 Stage Output (Btu/h): 283,000 / 56,700</p> <p>Min./Max. Gas Input - Pressure Natural or LP (in w.c): 2.5/14.0</p> <p>Gas Connection Pipe Size: 3/4"</p>		<p>COMPRESSOR</p> <p>Circuit(s)</p> <p>Number: 2</p> <p>Horsepower: 5.6/3.67</p> <p>Phase: 3</p> <p>Rated Load Amps: 9.6/6.0</p> <p>Locked Rotor Amps: 78.0/41.0</p>					
<p>INDOOR MOTOR</p> <p>Standard Motor</p> <p>Number: ⁽³⁾ 1</p> <p>Horsepower: 3.0</p> <p>Motor Speed (RPM): 1,740</p> <p>Phase: 3</p> <p>Full Load Amps: 3.9</p> <p>Locked Rotor Amps: 31.0</p>					<p>Standard Oversized Motor ⁽⁴⁾</p> <p>Number: -</p> <p>Horsepower: -</p> <p>Motor Speed (RPM): -</p> <p>Phase: -</p> <p>Full Load Amps: -</p> <p>Locked Rotor Amps: -</p>		<p>Accessory Oversized Motor ⁽⁴⁾</p> <p>Number: -</p> <p>Horsepower: -</p> <p>Motor Speed (RPM): -</p> <p>Phase: -</p> <p>Full Load Amps: -</p> <p>Locked Rotor Amps: -</p>
<p>OUTDOOR MOTOR</p> <p>Number: 1</p> <p>Horsepower: 0.5</p> <p>Motor speed (RPM): 1,100</p> <p>Phase: 1</p> <p>Full Load Amps: 1.3</p> <p>Locked Rotor Amps: 3.2</p>		<p>POWER EXHAUST (Field Installed Power Exhaust)</p> <p>Horsepower: N/A</p> <p>Motor Speed (RPM): N/A</p> <p>Phase: N/A</p> <p>Full Load Amps: N/A</p> <p>Locked Rotor Amps: N/A</p>		<p>COMBUSTION BLOWER MOTOR (Gas-Fired Heating only)</p> <p>Horsepower: -</p> <p>Motor Speed (RPM): -</p> <p>Phase: -</p> <p>Full Load Amps: -</p> <p>Locked Rotor Amps: -</p>			
<p>FILTER</p> <p>Type: Throwaway</p> <p>Furnished: Yes</p> <p>Number: 8</p> <p>Recommended Size: 20"x25"x2"</p>			<p>REFRIGERANT ⁽²⁾</p> <p>Circuit #1 / 2</p> <p>Type: R - 410</p> <p>Factory Charge</p> <p>Circuit #1 / 2: 9.7 lb / 6.2 lb</p>				

NOTES:

1. Maximum (HACR) Circuit Breaker sizing is for installations in the United States only.
2. Refrigerant charge is an approximate value. For a more precise value, see unit nameplate and service instructions.
3. Value include Standard Motor.
4. Value include Oversized Motor
5. EER is rated at AHRI conditions and in accordance with DOE test procedures.

Weight, Clearance & Rigging Diagram - Packaged Gas/Electric Rooftop Units
Item: B1 Qty: 1 Tag(s): RTU-1

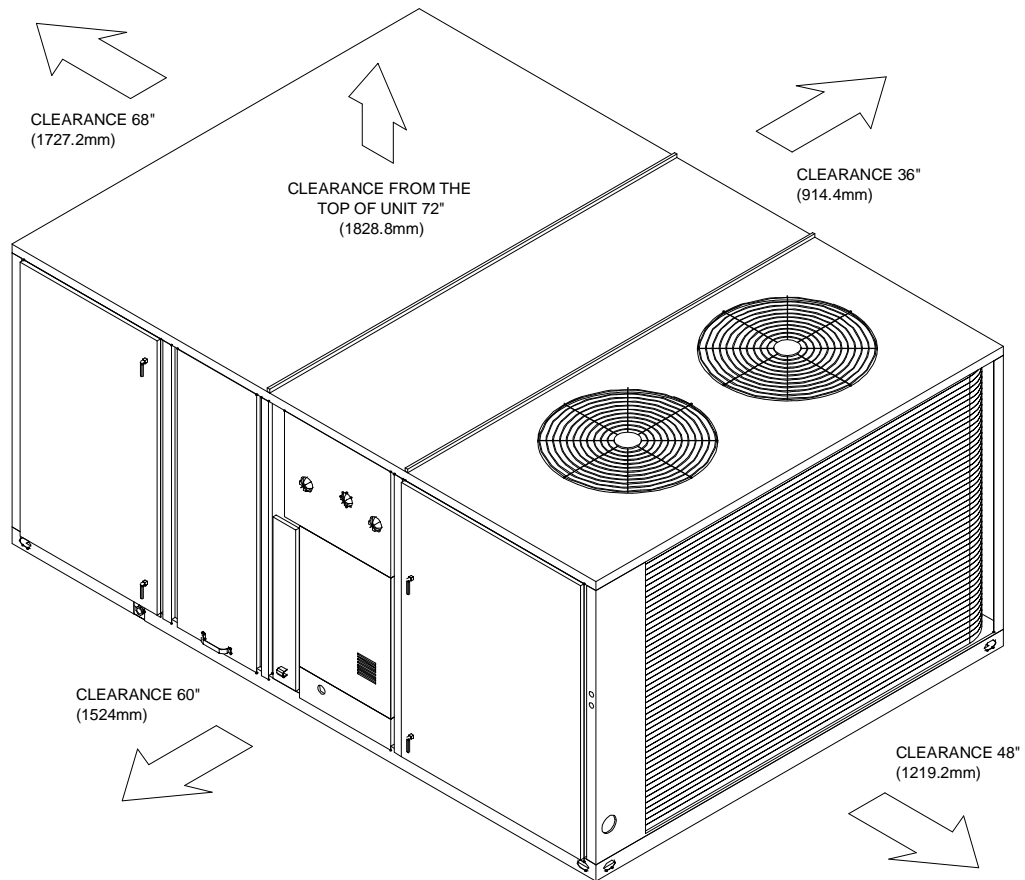

DOWNFLOW-PACKAGED GAS/ELECTRIC CLEARANCE

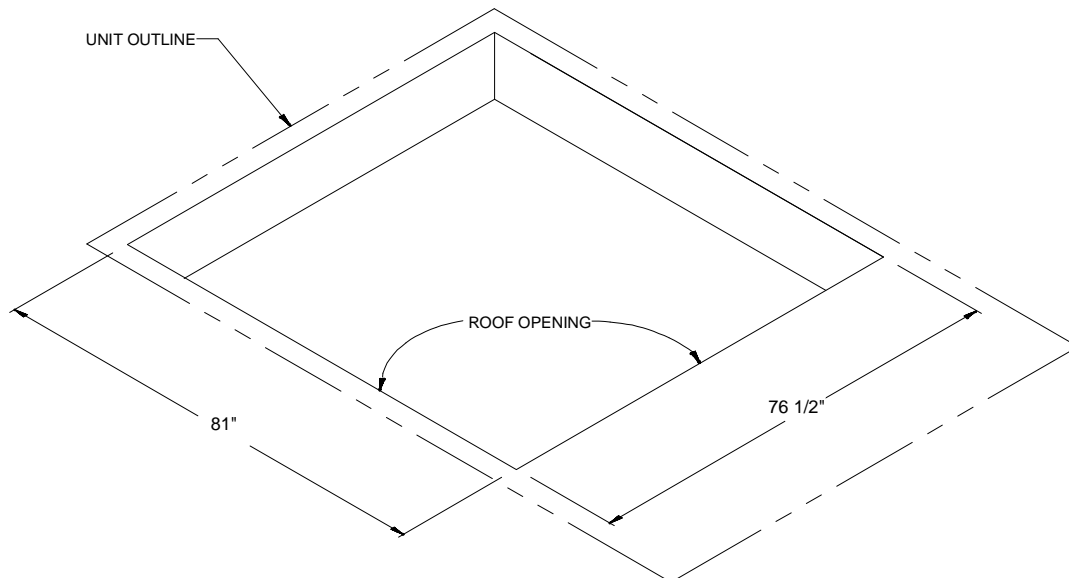

DOWNFLOW-PACKAGED GAS/ELECTRIC ROOF OPENING CLEARANCE

Weight, Clearance & Rigging Diagram - Packaged Gas/Electric Rooftop Units
Item: B1 Qty: 1 Tag(s): RTU-1

INSTALLED OPTIONS NET WEIGHT DATA

Accessory		Accessory					
Economizer		80.0 lb					
Motorized Outside Air Damper							
Manual Outside air Damper							
Oversized Motor							
High Static Drive							
Thru the Base Electrical		23.0 lb					
Unit Mounted Circuit Breaker							
Unit Mounted Disconnect		10.0 lb					
Power Exhaust		95.0 lb					
Hinged Doors		27.0 lb					
Zone Sensor		1.0 lb					
LPG Conversion Kit							
Powered Convenience Outlet							
Roof Curb							
BASE UNIT WEIGHTS		CORNER WEIGHTS				CENTER OF GRAVITY	
SHIPPING	NET	(A)	(B)	(C)	(D)	E	F
2610.0 lb	2126.0 lb	676.0 lb	555.0 lb	406.0 lb	487.0 lb	56"	36"

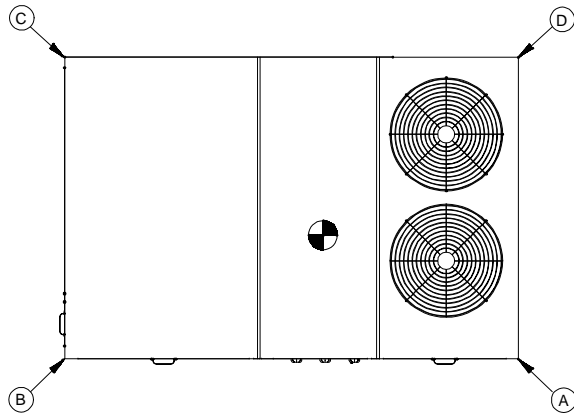

CORNER WEIGHT

NOTE:

1. CORNER WEIGHTS ARE GIVEN FOR INFORMATION ONLY.
2. TO ESTIMATE SHIPPING WEIGHT OF OPTION/ACCESSORIES ADD 5 LBS TO NET WEIGHT.
3. NET WEIGHT OF OPTIONAL ACCESSORIES SHOULD BE ADD TO UNIT WEIGHT WHEN ORDERING FACTORY INSTALLED ACCESSORIES.
4. WEIGHTS FOR OPTIONS NOT LISTED ARE < 5 LBS.
5. WEIGHT ARE OF BASE UNIT ONLY. FOR TOTAL WEIGHT, 10 DIGIT FACTORY INSTALLED OPTION (ECONOMIZER AND/OR OVERSIZED MOTOR OR FIOP/ACCESSORY WEIGHT MUST BE ADDED.

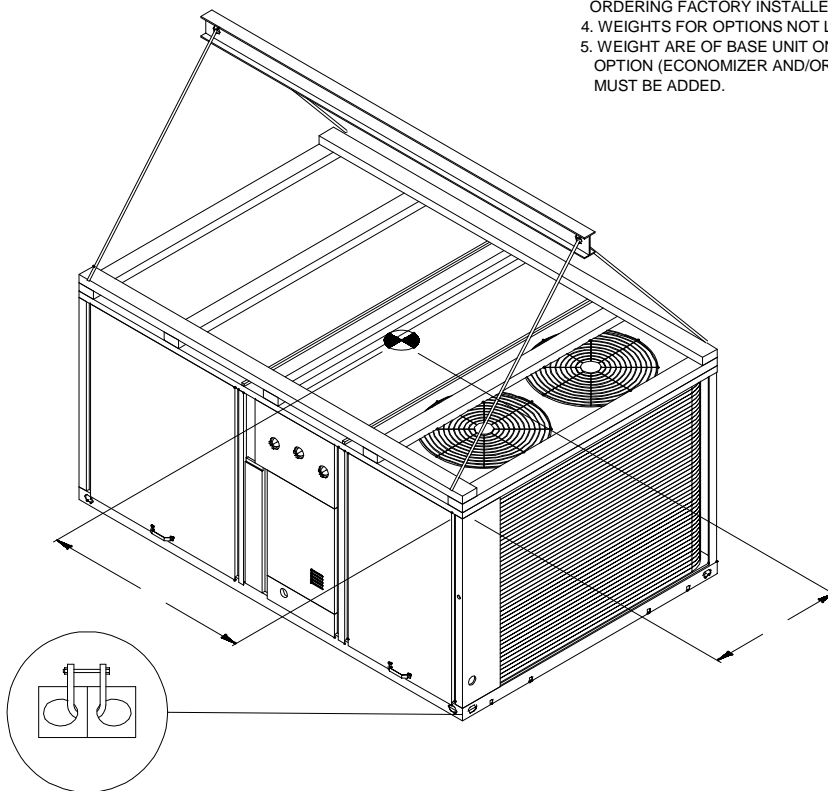

RIGGING AND CENTER OF GRAVITY

Weight, Clearance & Rigging Diagram - Packaged Gas/Electric Rooftop Units
Item: B1 - B3 Qty: 3 Tag(s): RTU-1, RTU-3, RTU-4

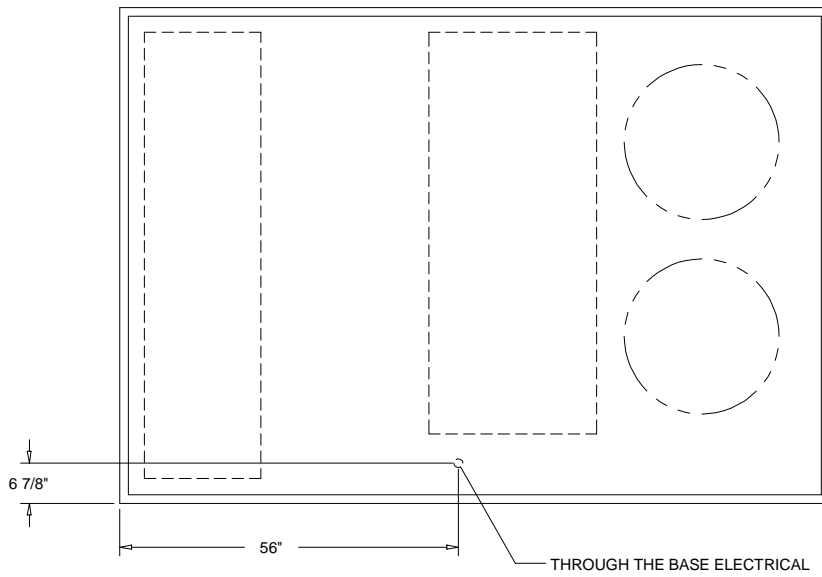

THROUGH THE BASE ELECTRICAL
ACCESSORY-PLAN VIEW

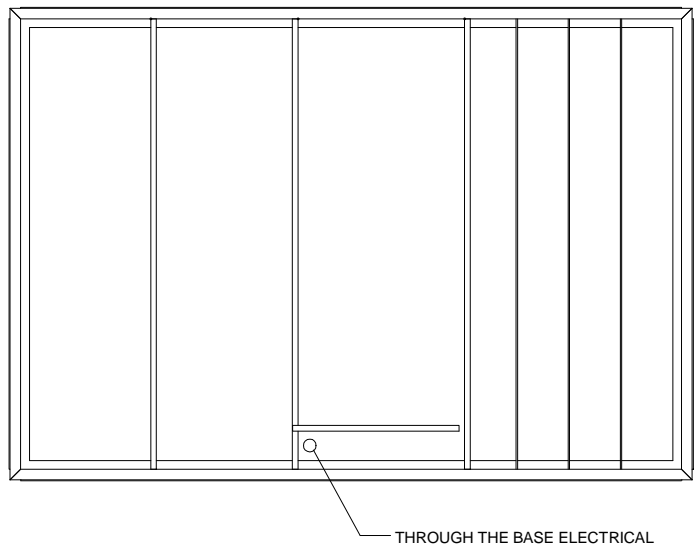

THROUGH THE BASE ELECTRICAL ROOF CURB
ACCESSORY-PLAN VIEW

Weight, Clearance & Rigging Diagram - Packaged Gas/Electric Rooftop Units
Item: B2, B3 Qty: 2 Tag(s): RTU-3, RTU-4

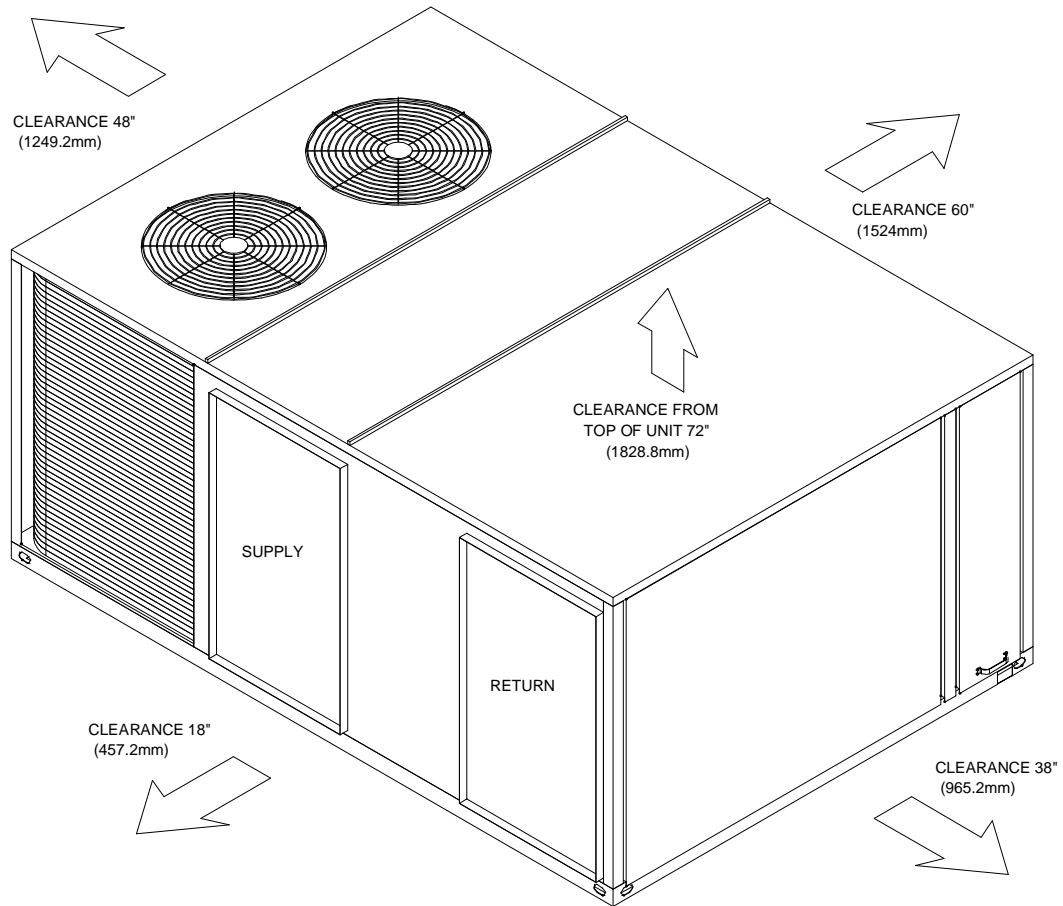

HORIZONTAL ISOMETRIC-PACKAGED GAS/ELECTRIC CLEARANCE

Weight, Clearance & Rigging Diagram - Packaged Gas/Electric Rooftop Units
 Item: B2, B3 Qty: 2 Tag(s): RTU-3, RTU-4

INSTALLED OPTIONS NET WEIGHT DATA

Accessory		Accessory					
Economizer		80.0 lb					
Motorized Outside Air Damper							
Manual Outside air Damper							
Oversized Motor							
High Static Drive							
Thru the Base Electrical		23.0 lb					
Unit Mounted Circuit Breaker							
Unit Mounted Disconnect		10.0 lb					
Power Exhaust							
Hinged Doors		27.0 lb					
Zone Sensor		1.0 lb					
LPG Conversion Kit							
Powered Convenience Outlet							
Roof Curb							
BASE UNIT WEIGHTS		CORNER WEIGHTS				CENTER OF GRAVITY	
SHIPPING	NET	(A)	(B)	(C)	(D)	E	F
2610.0 lb	2126.0 lb	676.0 lb	555.0 lb	406.0 lb	487.0 lb	56"	36"

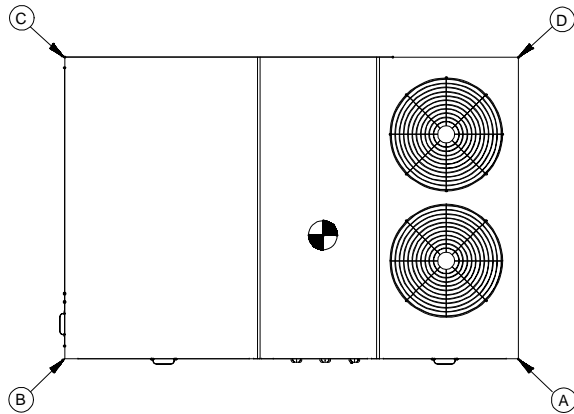

CORNER WEIGHT

NOTE:

1. CORNER WEIGHTS ARE GIVEN FOR INFORMATION ONLY.
2. TO ESTIMATE SHIPPING WEIGHT OF OPTION/ACCESSORIES ADD 5 LBS TO NET WEIGHT.
3. NET WEIGHT OF OPTIONAL ACCESSORIES SHOULD BE ADD TO UNIT WEIGHT WHEN ORDERING FACTORY INSTALLED ACCESSORIES.
4. WEIGHTS FOR OPTIONS NOT LISTED ARE < 5 LBS.
5. WEIGHT ARE OF BASE UNIT ONLY. FOR TOTAL WEIGHT, 10 DIGIT FACTORY INSTALLED OPTION (ECONOMIZER AND/OR OVERSIZED MOTOR OR FIOP/ACCESSORY WEIGHT MUST BE ADDED.

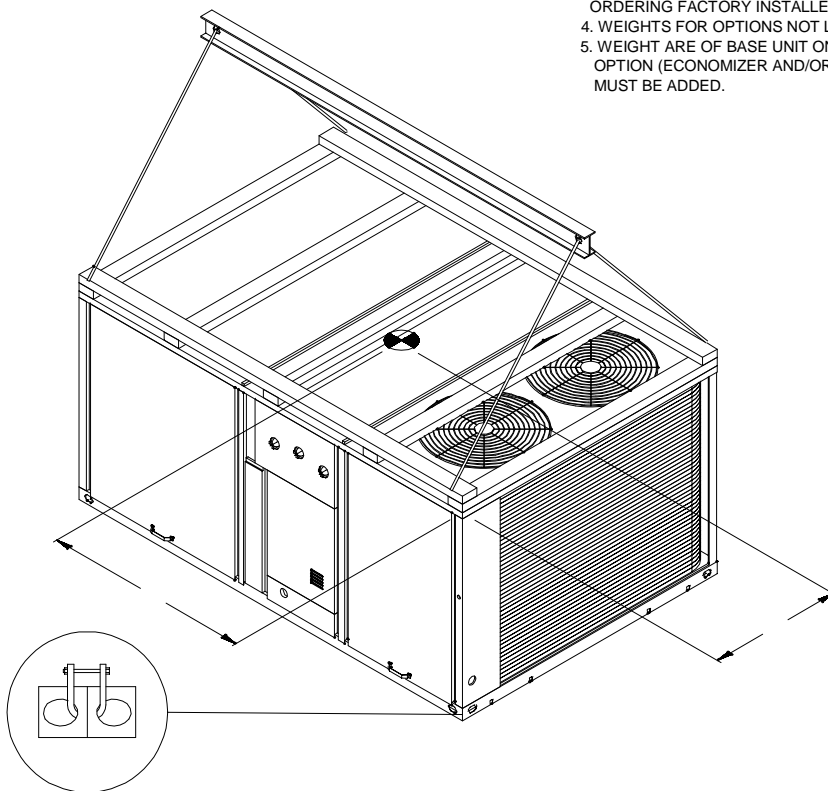

RIGGING AND CENTER OF GRAVITY

Accessory - Packaged Gas/Electric Rooftop Units
Item: B1 Qty: 1 Tag(s): RTU-1

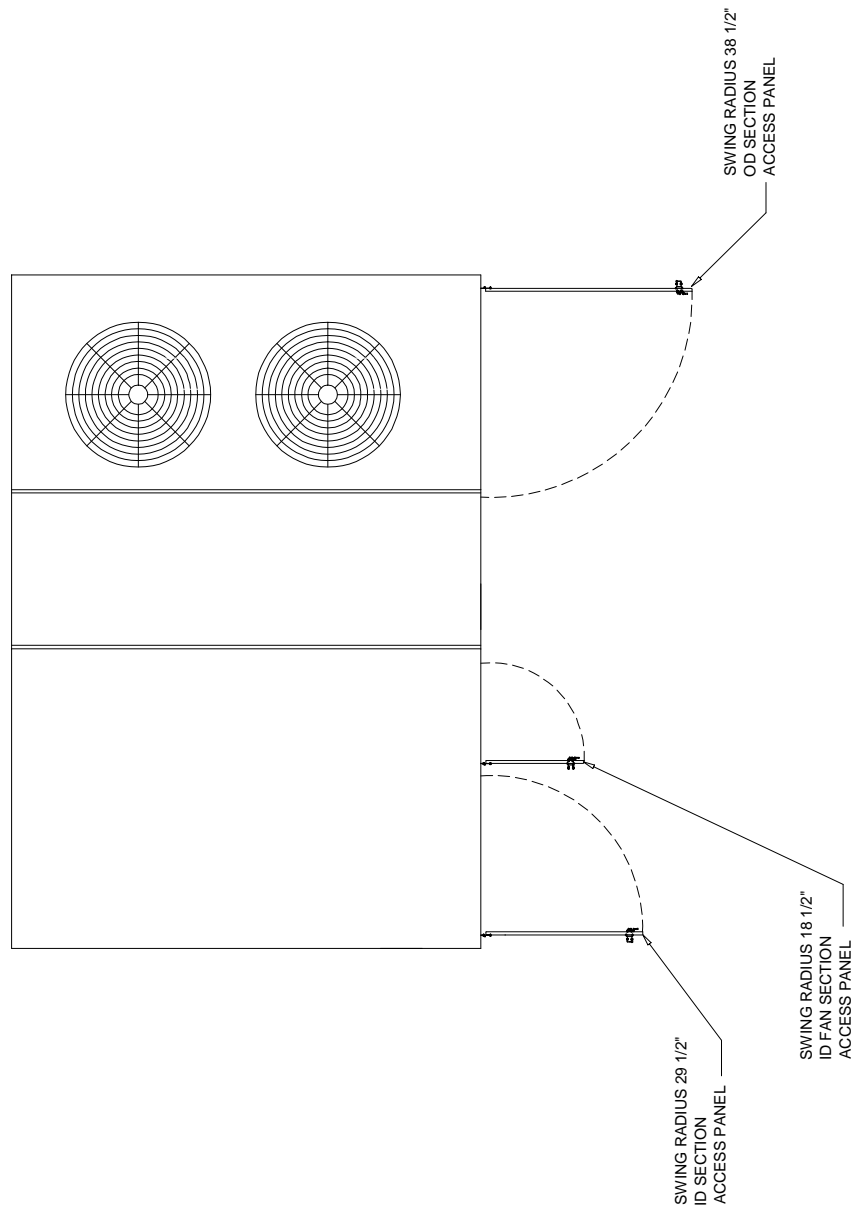

ACCESSORY-HINGGING ACCESS DOORS

Accessory - Packaged Gas/Electric Rooftop Units
Item: B1 Qty: 1 Tag(s): RTU-1

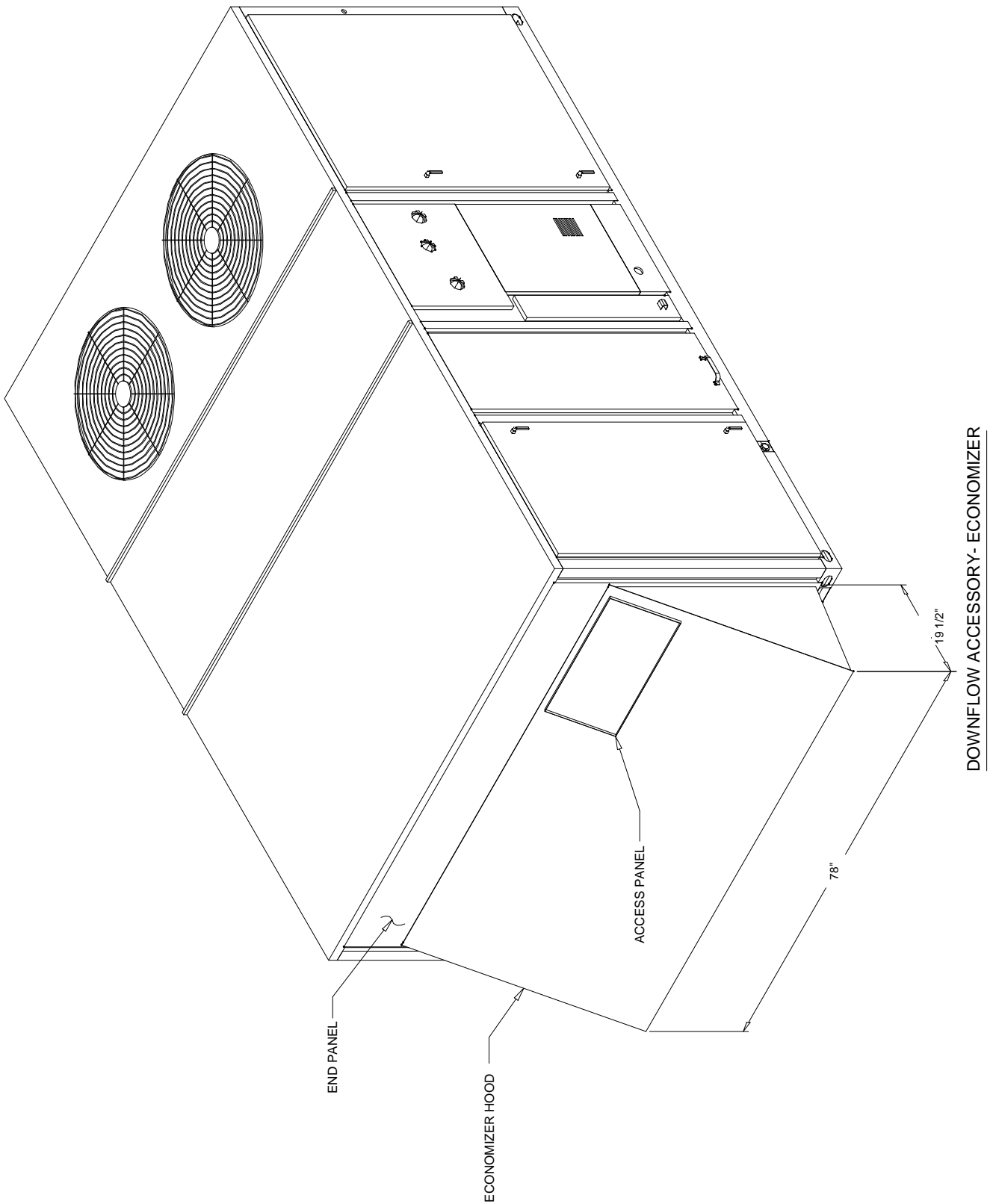

Accessory - Packaged Gas/Electric Rooftop Units
Item: B1 Qty: 1 Tag(s): RTU-1

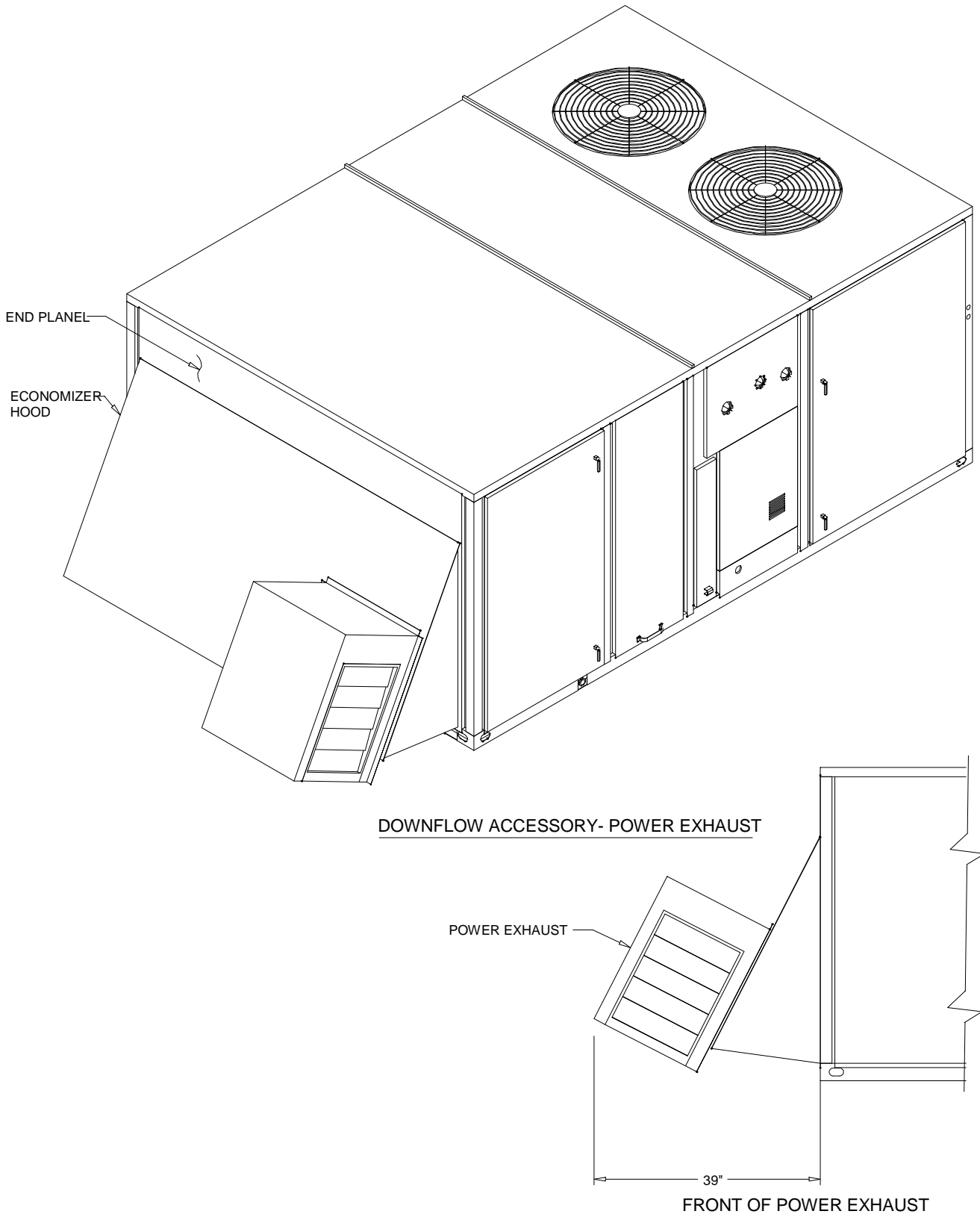

Accessory - Packaged Gas/Electric Rooftop Units
Item: B1 Qty: 1 Tag(s): RTU-1

* US PATENTS 5188333, 5255887
 CANADIAN PATENT 2073900
 ADDITIONAL PATENTS PENDING

TO SUIT
TRANE
 BAYCURB027B

FEATURES:

- HEAVY GAUGE GALVANIZED STEEL CONSTRUCTION
- 2 x 3" WOOD PERIMETER NAILER
- PATENTED CLIPLOCK DESIGN FOR EASE OF ASSEMBLY
- NEOPRENE GASKET

OPTIONS:

- CUSTOM OR OPTIONAL 18", AND 24" HEIGHTS
- STAINLESS STEEL OR ALUMINUM CONSTRUCTION
- INTERNAL 1" INSULATION

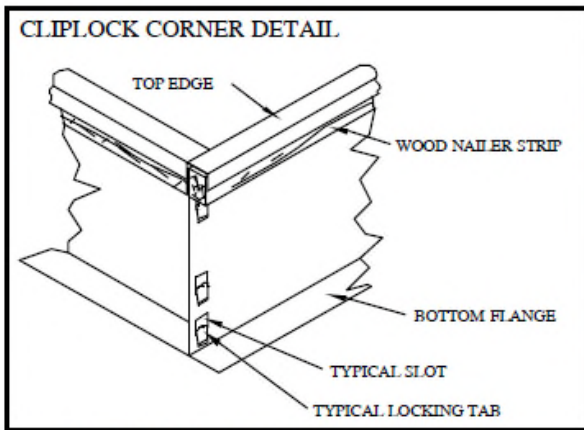

NOTE: SEE CLIPLOCK 1000 INSTALLATION INSTRUCTIONS FOR COMPLETE ASSEMBLY AND INSTALLATION PROCEDURES AND REQUIREMENTS.

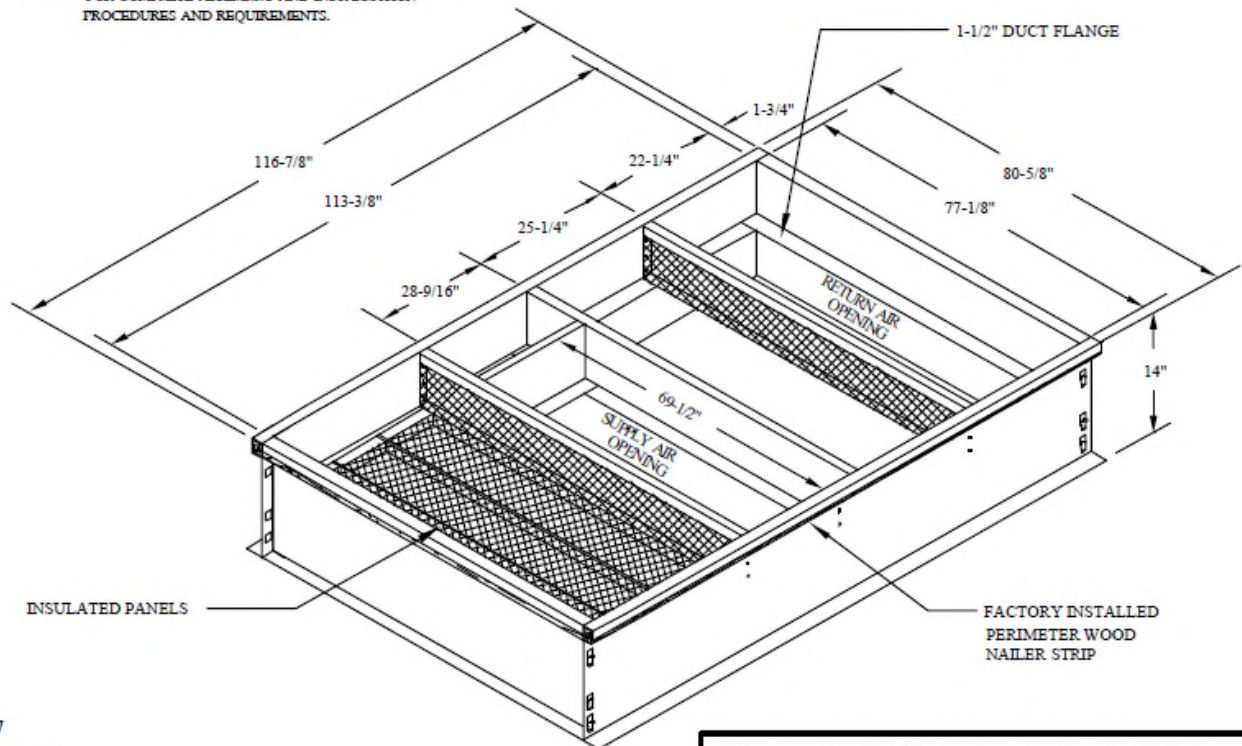

TR127

27 Leading Road Etobicoke, Ontario, Canada M0V 4R7

**** Drawing shows 14" high curb but 18" curbs will be provided at site.**

Accessory - Packaged Gas/Electric Rooftop Units
Item: B1 Qty: 1 Tag(s): RTU-1

TRANE
BAYCURB027

FEATURES:

- DESIGNED TO FIT ON STANDARD CURBS
- ONE PIECE FULLY ASSEMBLED CONSTRUCTION
- HEAVY GAUGE STEEL
- MITERED CORNERS, CONTINUOUSLY WELDED TO GUARD AGAINST WATER LEAKAGE
- FLEXIBLE NON-ABRASIVE WEATHER SEAL
- FREE STANDING 1" DEFLECTION SPRINGS WITH LACQUER BASED POLY-VINYLL FINISH
- NEOPRENE COVERED NON-SKID SPRING BASE PLATE WITH RAISED ACOUSTICAL CUP
- SUPPLY AND RETURN AIR OPENING FLEX CONNECTORS

CAUTION:
 THIS ACCESSARY MAY REQUIRE RE-ENGINEERING IF POWER EXHAUST IS UTILIZED.

ALL OR A PORTION OF THE COMPONENTS CONTAINED ON THIS DRAWING MAY BE PROTECTED BY PATENT NUMBERS 5188333, 5255887, 2073900.

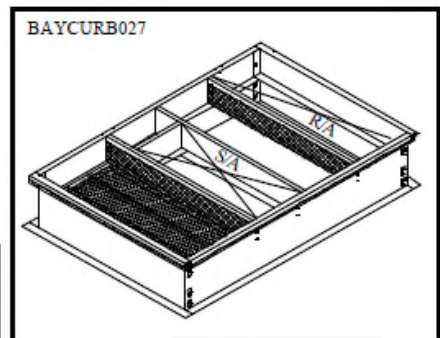
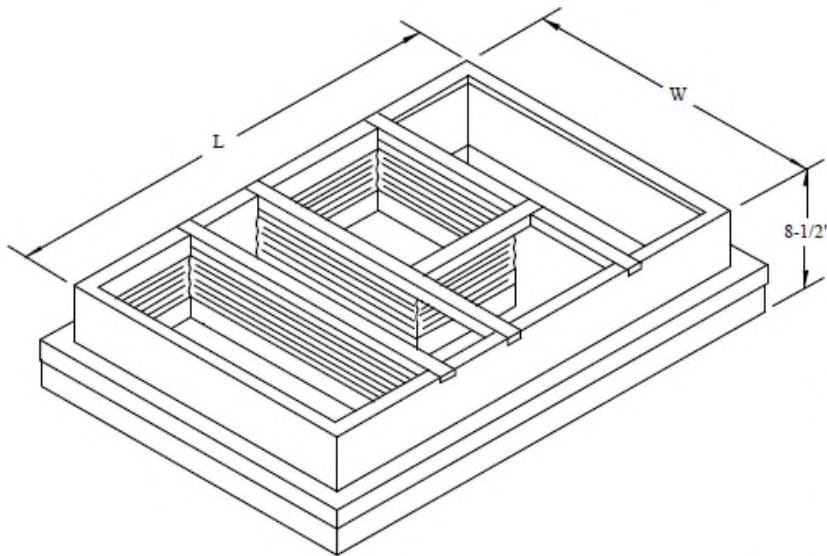
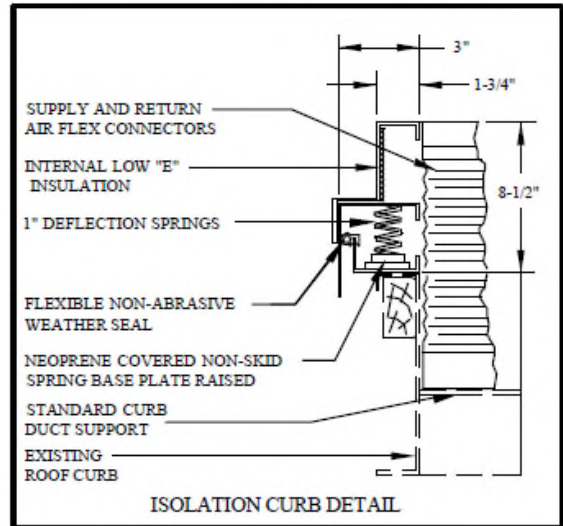

MODEL	USE WITH	L	W
BAYCURB027	VOYAGER SERIES	116-7/8"	80-5/8"

Accessory - Packaged Gas/Electric Rooftop Units
Item: B1 - B3 Qty: 3 Tag(s): RTU-1, RTU-3, RTU-4

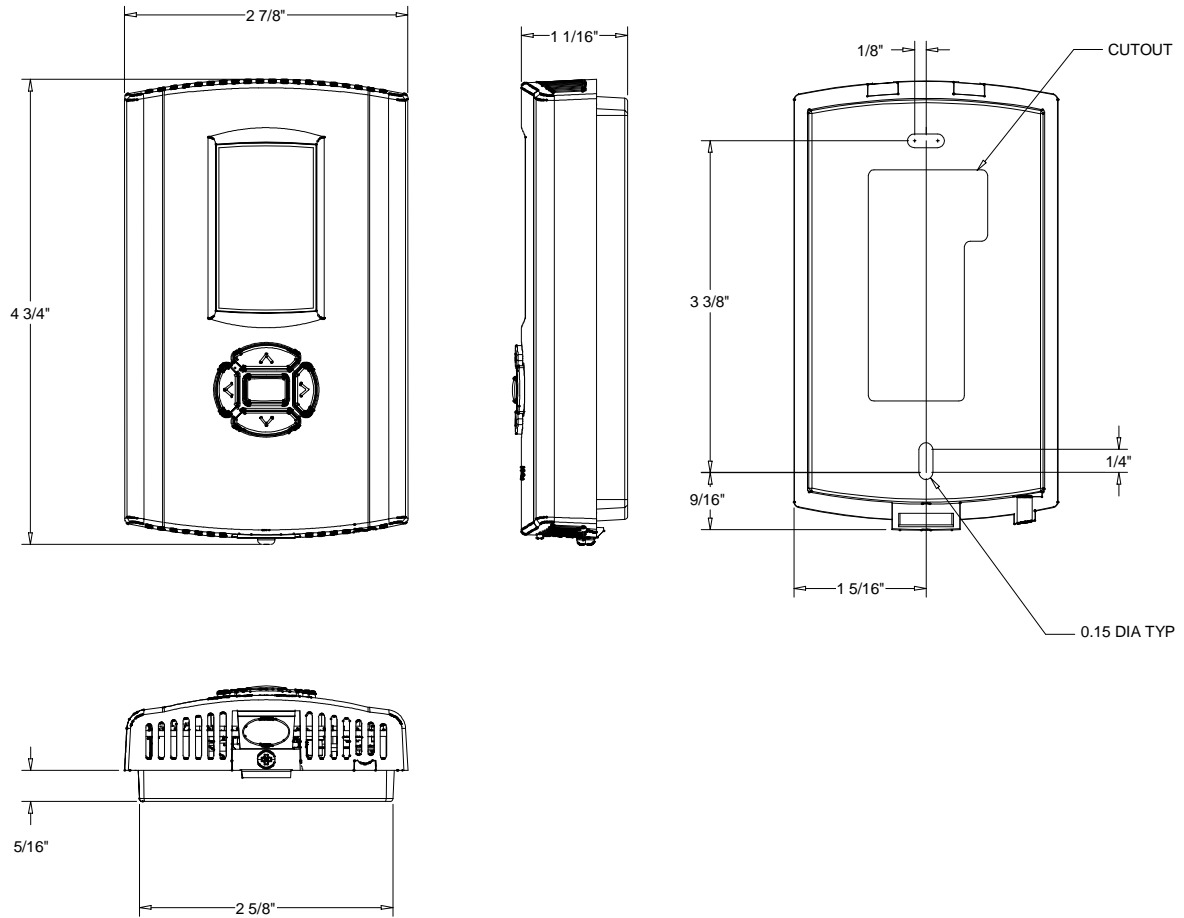

BAYSEN135 - ZONE SENSOR
DIGITAL LCD

Accessory - Packaged Gas/Electric Rooftop Units
Item: B2, B3 Qty: 2 Tag(s): RTU-3, RTU-4

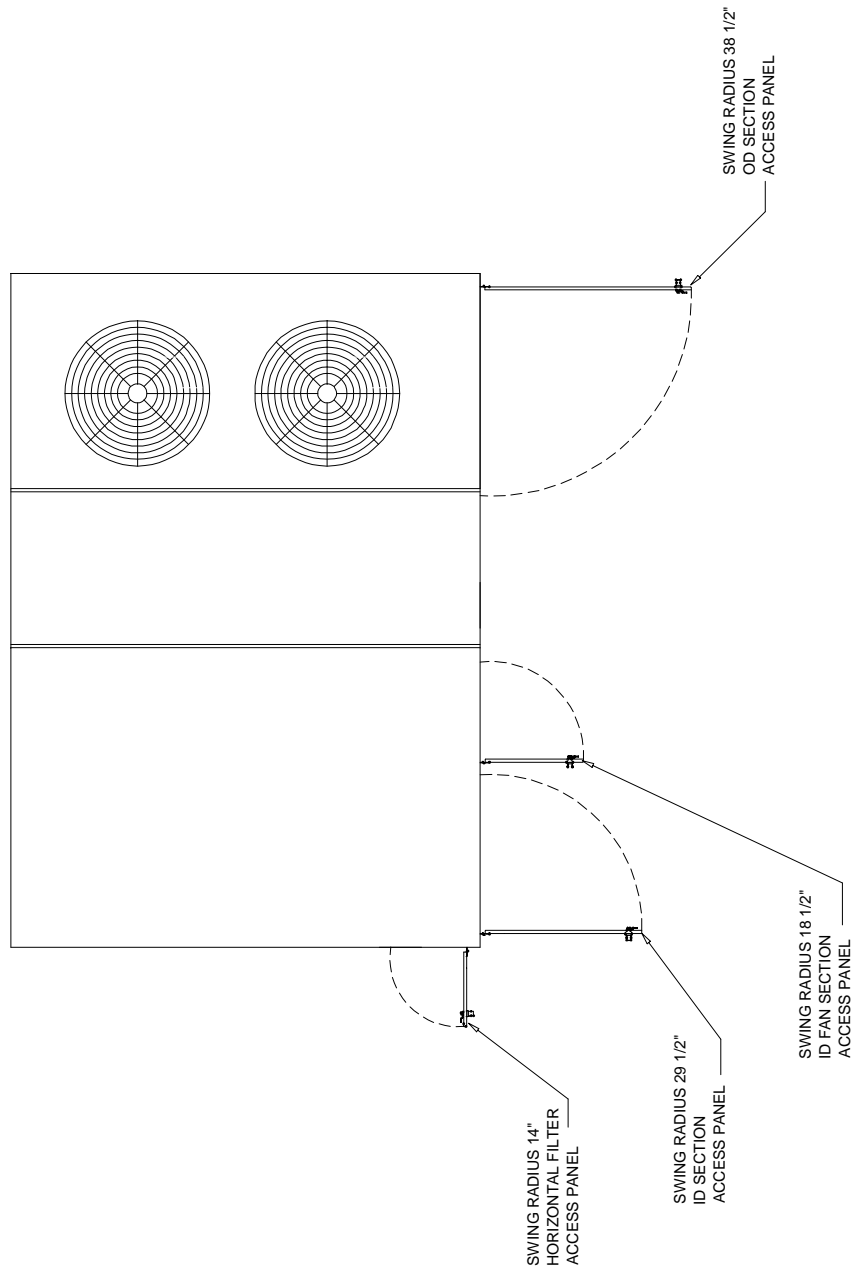

ACCESSORY-HINGGING ACCESS DOORS

Accessory - Packaged Gas/Electric Rooftop Units
Item: B2, B3 Qty: 2 Tag(s): RTU-3, RTU-4

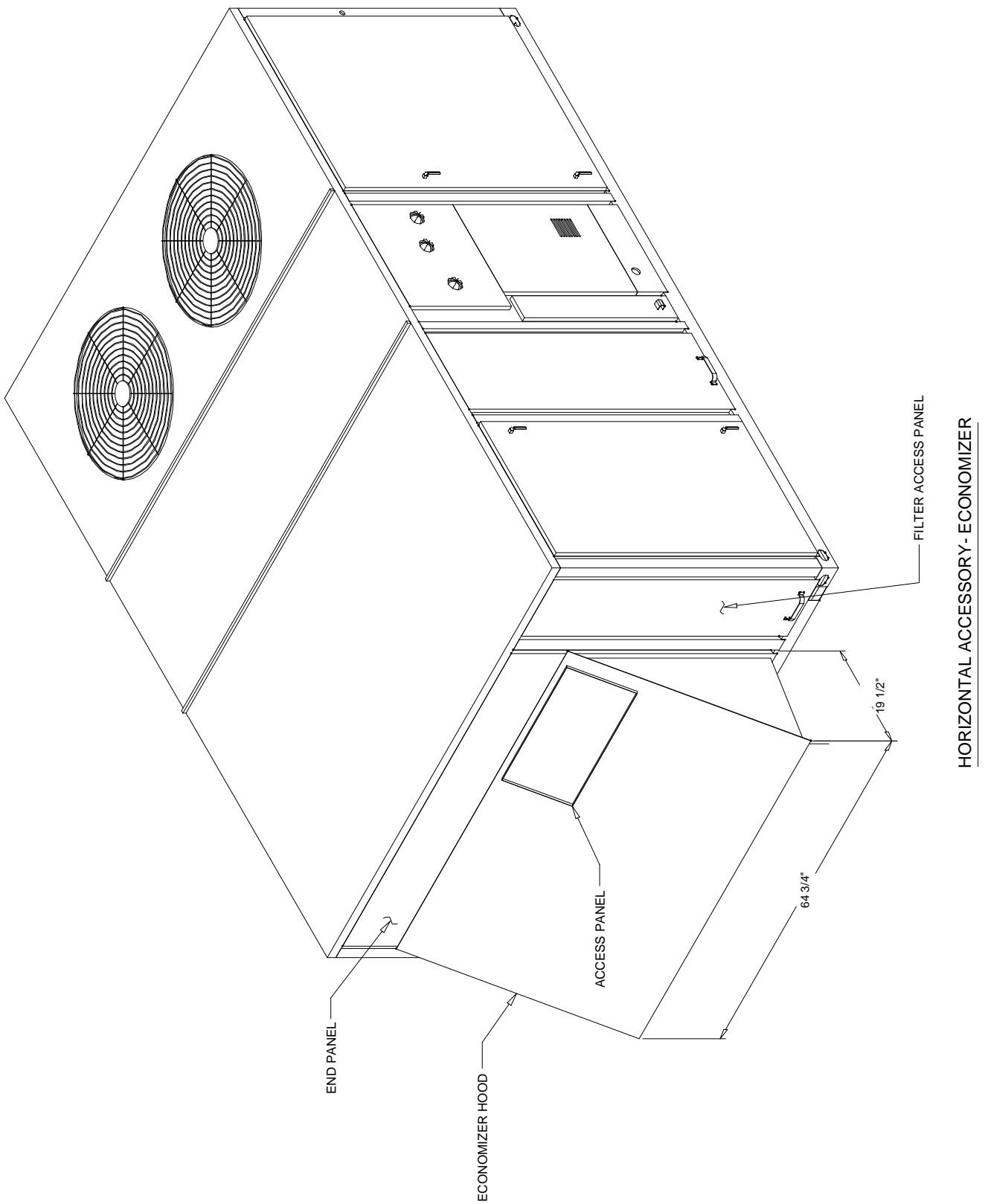

Accessory - Packaged Gas/Electric Rooftop Units
Item: B2, B3 Qty: 2 Tag(s): RTU-3, RTU-4

* US PATENTS 5188333, 5255887
 CANADIAN PATENT 2073900
 ADDITIONAL PATENTS PENDING

TO SUIT
TRANE
 BAYCURB027B

FEATURES:

- HEAVY GAUGE GALVANIZED STEEL CONSTRUCTION
- 2 x 3" WOOD PERIMETER NAILER
- PATENTED CLIPLOCK DESIGN FOR EASE OF ASSEMBLY
- NEOPRENE GASKET

OPTIONS:

- CUSTOM OR OPTIONAL 18", AND 24" HEIGHTS
- STAINLESS STEEL OR ALUMINUM CONSTRUCTION
- INTERNAL 1" INSULATION

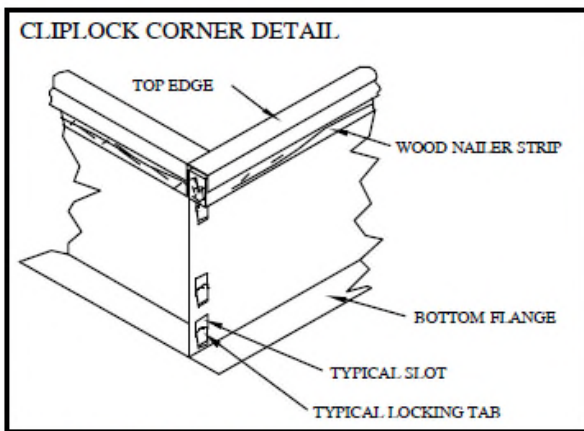

NOTE: SEE CLIPLOCK 1000 INSTALLATION INSTRUCTIONS FOR COMPLETE ASSEMBLY AND INSTALLATION PROCEDURES AND REQUIREMENTS.

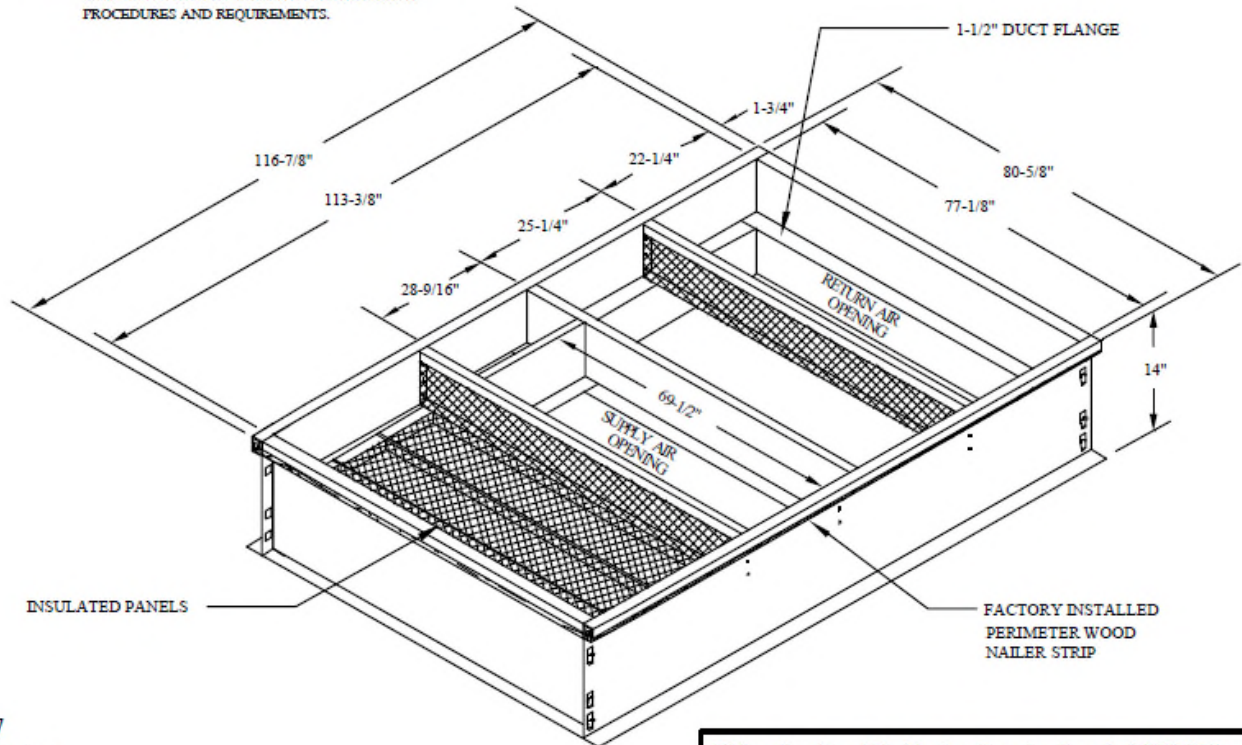

TR127

077-00-104

27 Leading Road Etobicoke, Ontario, Canada M0V 4R7

**** Drawing shows 14" high curb but 18" curbs will be provided at site.**

Accessory - Packaged Gas/Electric Rooftop Units
Item: B2, B3 Qty: 2 Tag(s): RTU-3, RTU-4

FEATURES:

- DESIGNED TO FIT ON STANDARD CURBS
- ONE PIECE FULLY ASSEMBLED CONSTRUCTION
- HEAVY GAUGE STEEL
- MITERED CORNERS, CONTINUOUSLY WELDED TO GUARD AGAINST WATER LEAKAGE
- FLEXIBLE NON-ABRASIVE WEATHER SEAL
- FREE STANDING 1" DEFLECTION SPRINGS WITH LACQUER BASED POLY-VYNYL FINISH
- NEOPRENE COVERED NON-SKID SPRING BASE PLATE WITH RAISED ACOUSTICAL CUP
- SUPPLY AND RETURN AIR OPENING FLEX CONNECTORS

CAUTION:
 THIS ACCESSARY MAY REQUIRE RE-ENGINEERING IF POWER EXHAUST IS UTILIZED.

ALL OR A PORTION OF THE COMPONENTS CONTAINED ON THIS DRAWING MAY BE PROTECTED BY PATENT NUMBERS 5188333, 5255887, 2073900.

TRANE

BAYCURB027

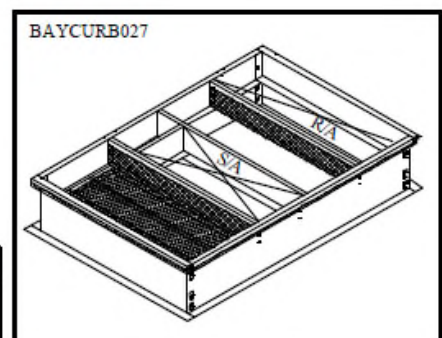
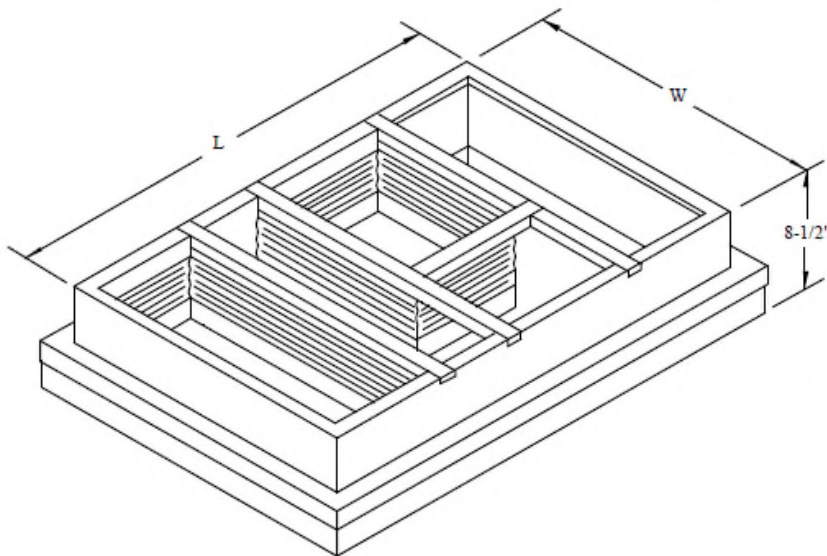
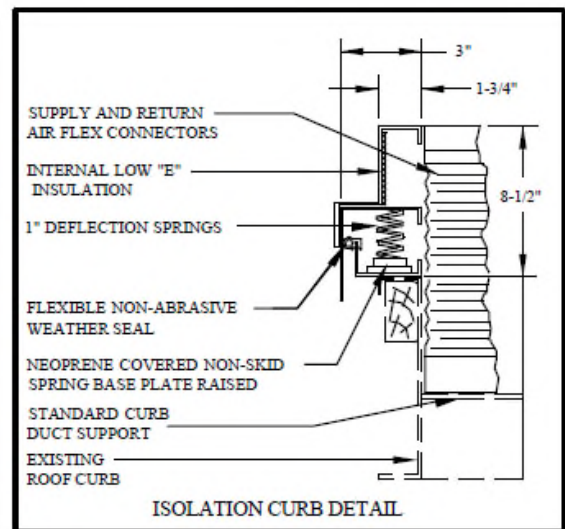

MODEL	USE WITH	L	W
BAYCURB027	VOYAGER SERIES	116-7/8"	80-5/8"

Accessory - Packaged Gas/Electric Rooftop Units
Item: B2, B3 Qty: 2 Tag(s): RTU-3, RTU-4

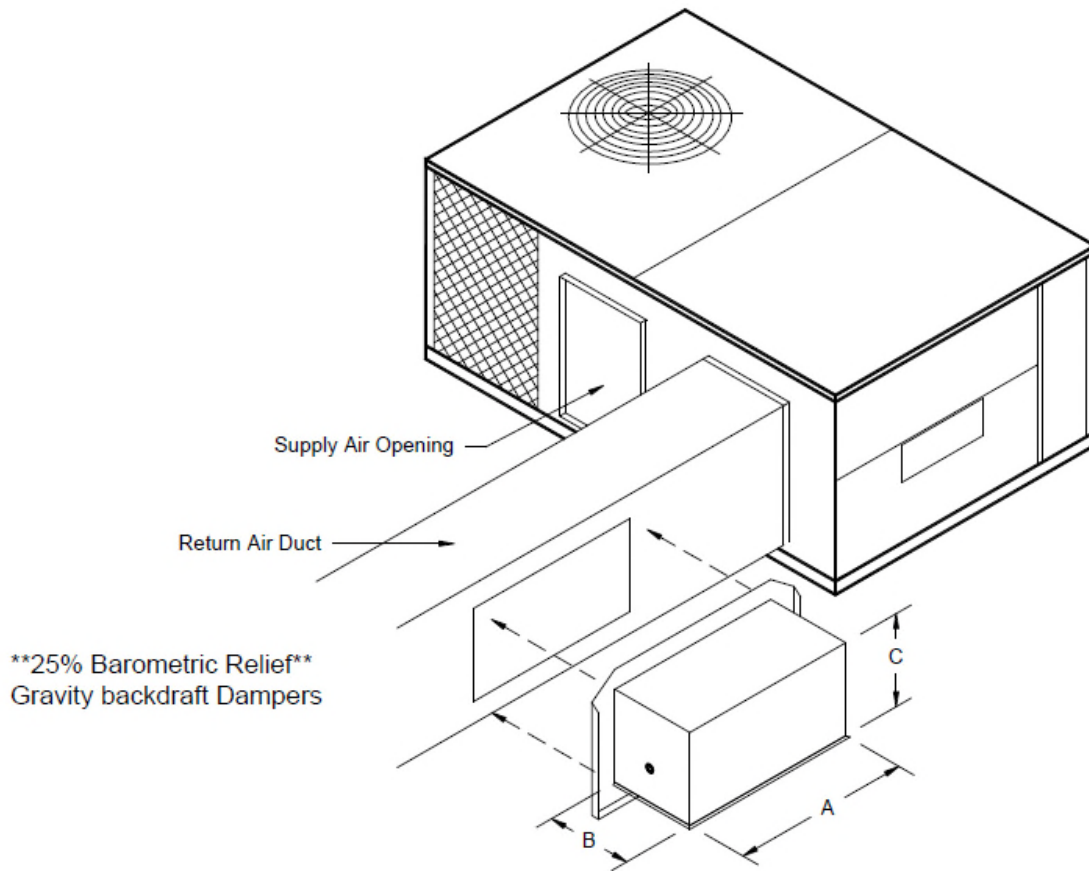

Qty.	Trane Model Number	ThyCurb #	A	B	C	Tag:
	Y/TCH 150E	TR5BRH00126	22	12	12	
	Y/TCH151E,180E,181E,210E,211E,240E,241E,300E,301E WCH 150E,180E,240E	TR5BRH00127	30	12	12	

Field Installed Options - Part/Order Number Summary

This is a report to help you locate field installed options that arrive at the jobsite. This report provides part or order numbers for each field installed option, and references it to a specific product tag. It is NOT intended as a bill of material for the job.

Product Family - 3-10 Ton R410A PKGD Unitary Gas/Electric Rooftop

Item	Tag(s)	Qty	Description	Model Number
A1	RTU-2	1	7.5 Ton R410A PKGD Unitary Gas/Electric	YHC092FWRYA--

Field Installed Option Description	Part/Ordering Number
Roof curb	BAYCURB043A
Digital display zone sensor	BAYSENS135A

Product Family - Packaged Gas/Electric Rooftop Units

Item	Tag(s)	Qty	Description	Model Number
B1	RTU-1	1	12 1/2 Ton Packaged Unitary Gas/Ele	YHD150GWRVA--

Field Installed Option Description	Part/Ordering Number
Power exhaust	BAYPWRX031B
0-100% Economizer, dry bulb control	BAYECON090B
Digital display zone sensor	BAYSENS135A
Comparative enthalpy kit	BAYENTH008B
Shaft grounding ring 1.125"	BAYSHGR002A

Item	Tag(s)	Qty	Description	Model Number
B2	RTU-3	1	12 1/2 Ton Packaged Unitary Gas/Ele	YHH150GWRVA--

Field Installed Option Description	Part/Ordering Number
Digital display zone sensor	BAYSENS135A
Comparative enthalpy kit	BAYENTH008B
0-100% Economizer, dry bulb control	BAYECON092B
Shaft grounding ring 1.125"	BAYSHGR002A

Item	Tag(s)	Qty	Description	Model Number
B3	RTU-4	1	12 1/2 Ton Packaged Unitary Gas/Ele	YHH150GWRVA--

Field Installed Option Description	Part/Ordering Number
0-100% Economizer, dry bulb control	BAYECON092B
Comparative enthalpy kit	BAYENTH008B
Digital display zone sensor	BAYSENS135A